

# Operating Instructions e@syDrive 4425, 4426.



Always on the safe side.



*With Compliments*

**CENTERLINE INC.**  
PRECISION SPINDLE ENGINEERING

2110 N. Ash • Ponca City, OK 74601  
Bus: 580-762-5451 • Fax: 580-762-4722  
e-mail: [info@centerline-inc.com](mailto:info@centerline-inc.com) • [www.centerline-inc.com](http://www.centerline-inc.com)



KaVo.Drive Systems

**KaVo Elektrotechnisches Werk GmbH**  
Wangener Straße 78  
D-88299 Leutkirch  
Tel.: 0 75 61 / 86-0 • Fax: 0 75 61 / 86-371



# e@syDrive 4425, 4426.

<b>A 1 User information</b>	<b>3</b>
A 1.1 Meaning of the pictograms	3
A 1.2 Important information	3
A 1.3 Precautions	4
A 1.4 Purpose and potential applications	6
A 1.5 Technische Daten Umrichter e@syDrive 4425	7
A 1.5 Technical Data Inverter e@syDrive 4426	9
<b>A 2 Scope of delivery - Accessories</b>	<b>11</b>
A 2.1 Scope of delivery	11
A 2.2 Accessories	11
<b>A 3 Operational elements</b>	<b>12</b>
A 3.1 Rating plate 3	12
<b>A 4 Description of function</b>	<b>13</b>
A 4.1 Three-phase asynchronous motor (ASM)	13
A 4.2 Brushless DC motor without sensors (BLDC)	13
A 4.3 Brushless DC motor with position sensors (BLDCS)	13
A 4.4 Remote control	13
A 4.5 Motor codes via inputs IN2...IN6 to X5:	16
A 4.6 Setpoint value selection	17
A 4.7 Emergency motor stop at Power failure	18
A 4.8 Counterclockwise operation	18
A 4.9 Wiring diagram	19

# e@syDrive 4425, 4426.

<b>B 1 Assembly and Installation</b> .....	<b>20</b>
B 1.1 Assembly .....	20
B 1.2 Electrical Installation .....	21
B 1.3 Wiring guidelines for compliance with the EMC standards .....	21
B 1.4 Electrical connections .....	22
<b>B 2 Description of the Installation Assistant e@syDrive 4425/4426</b> .....	<b>25</b>
B 2.1 Tasks of the Installation Assistant .....	26
B 2.2 Installing the Installation Assistant in various operating systems .....	27
Windows 98 / 2nd Edition .....	30
Windows 2000 .....	32
Windows ME .....	33
Windows NT .....	35
Windows XP .....	38
<b>B 3 Operating software</b> .....	<b>39</b>
B 3.1 Language .....	39
B 3.2 Basic parameters .....	40
B 3.3 Help data .....	40
B 3.4 Window – display values .....	41
B 3.5 Window – Remote control .....	41
B 3.6 Window - Motor parameters .....	42
B 3.7 U/f-Tabelle .....	42
B 3.8 Motor-control parameters .....	43
B 3.9 Window – Special programmes .....	43
<b>B 4 Configuration</b> .....	<b>44</b>
B 4.1 Special functions .....	45
B 4.2 Aktor-sensor Test .....	45
B 4.3 Complete parameter structure .....	46
B 4.4 Factory setting .....	46
B 4.5 Technical Service .....	46
B 4.6 Parameter list .....	47
<b>Description of the individual parameters</b> .....	<b>49</b>
B 4.7 Basic parameters .....	49
B 4.8 Display value .....	49
B 4.8 Motor operating values .....	51
B 4.10 Motor U/f-characteristic .....	54
B 4.11 Control .....	55
B 4.12 Monitoring .....	58
B 4.13 Nominal motor values .....	58
B 4.14 Device parameters, remote control .....	59
<b>B 5 Error messages</b> .....	<b>63</b>
B 5.1 Hold function .....	63
B 5.2 Faults and Warnings .....	63
B 5.3 Description of all errors and warnings .....	64
<b>Warranty conditions</b> .....	<b>67</b>
<b>CE Declaration of conformity</b> .....	<b>67</b>

## A 1 User information

### A 1.1 Meaning of the pictograms



*Situation which may lead to danger, damage to material or operating faults in the event of failure to follow the instructions.*



*Important information for operator and engineer.*

### A 1.2 Important information



*The User Manual must be read by the user/operator prior to commissioning, in order to avoid incorrect operation and other damage. Duplication and distribution of the User Manual (UM) require prior consent from KaVo.*

All technical data, information and properties of the product described in this UM correspond to the state on going to press.

Modifications and improvements to the product on the basis of new technical developments are possible.

This does not imply any right to retrofitting of existing devices.

KaVo assumes no responsibility for damage arising through:

- external influences (poor quality of the media or poor installation)
- use of incorrect information
- improper use
- improperly performed repairs.

Repair and maintenance work - except for the activities described in this User Manual - may be performed only by qualified specialists.

In the event of modifications by third parties, the approvals shall become null and void. KaVo recommends using only original spare parts for operation and for repair.



*For safety reasons, the inverter supplied has been configured to operating mode “no motor” Since it is not known which motor will be connected, an incorrect configuration could damage or destroy the motor or the inverter.*

*In order to configure the inverter, please read Section B3.*

## A 1.3 Precautions

Safe operation and protection of the device is ensured only by proper use, in accordance with the User Manual, with the tools approved for this purpose. The following should also be observed:

- the work safety regulations,
- the accident prevention regulations.

Before installation and commissioning of this device, please read this safety and warning information carefully and observe all warning signs mounted on the device.



- *The frequency inverter type 4425/4426 controls dangerously rotating mechanical parts. If these Operating Instructions are not followed, severe damage to property, injuries and even death may result.*
- *Safe operation of this device depends on the proper installation, handling and operation of the device.*
- *Only appropriately qualified personnel may put this device into operation, maintain it and work on it. Connection, commissioning and rectification of faults may be performed only by specialists.*
- *The device has no mains switch. When working on the open device, it must be completely disconnected from the mains beforehand. The device has no mains input fuses.*
- *This device may start up automatically with certain settings after a mains failure.*
- *This device may not be used as an “emergency stop mechanism” (see EN 60204).*
- *The device may be used only for the purpose intended by the manufacturer. Unauthorized modifications and the use of additional equipment not recommended by the manufacturer can cause fires, electric shocks and injuries.*

## Definitions

<b>ASM motor</b>	3-phase asynchronous motor
<b>BLDC-Motor</b>	3-phase brushless DC motor without position sensors The inverter performs the position synthesis by measuring the motor voltage (e.m.f.).
<b>BLDCS-Motor</b>	3-phase brushless DC motor with position sensors
<b>EEPROM</b>	Electrically Erasable Program Memory. In the EEPROM, all important alterable data (parameters, calibration values) of the frequency inverter type 4425/4426 are stored and the data remain stored even during a voltage failure.
<b>Danger</b>	In the context of this User Manual and of the warnings mounted on the device, this means that death, serious injury or considerable damage to property may occur if the corresponding precautions are not taken.
<b>Note</b>	In the context of this User Manual, a note constitutes important information which is of particular importance for the understanding and the operation of the device.
<b>PC Browser-Operation</b>	The configuration and , as required, the operation of the inverter is carried out using a standard PC Browser (MS-Internet-Explorer).
<b>DFÜ</b>	Data transmission
<b>RAS- Modem</b>	Remote Access Service (Fern-Zugangs-Dienst)
<b>Microstep startup</b>	With microstep startup, the BLDC motor is operated as a synchronous motor with constant current. The output frequency is slowly increased from 0 Hz to the startup frequency, after which the system switches to regulated motor running. The microstep startup permits startup of sensor-free BLDC motor with large centrifugal masses (e.g. vacuum pumps) for which the normal startup fails owing to the large mass moment of inertia.
<b>Normal state</b>	If no error occurs after switching on, the standard display appears on the LCD display H1 and the LED H3 “Operation” (green) lights up. This machine state is called the normal state. By repeatedly pressing the key ← (cancel, transfer), it is possible to exit the state and return to it.

## e@syDrive 4425, 4426.

<b>Configuration</b>	Configuration is the operating procedure for setting up the inverter for use, motor settings and device-specific settings being implemented via the control panel. It is also possible to display different measured values.
<b>Qualified personnel</b>	are in the context of this User Manual persons who are familiar with the installation, assembly, commissioning and operation of the product and with the possible dangers.
<b>Standard display</b>	With parameter <code>P4-display</code> , the value or the value combination (combi display) which is displayed in the normal state can be selected. This is the standard display.
<b>Caution</b>	In the context of the User Manual and of the warning signs mounted on the device, this means that slight injury or damage to property may occur if the corresponding precautions are not taken.
<b>Warning</b>	In the context of the User Manual and of the warning signs mounted on the device, this means that death, serious injury and considerable damage to property may occur if the corresponding precautions are not taken.
<b>URL</b>	Uniform Resource Locator /Address details in browser command lines.
<b>IP-Adress</b>	Internet Protokoll Adress

## A 1.4 Purpose and potential applications

KaVo frequency inverters, type 4452, have been specially constructed for the operation of three-phase asynchronous motors (ASM) and brushless DC motors (BLDC), as used in spindles, e.g. for grinding, cutting and drilling units on machine tools.

They can also be used for operating motors which are constructed from motor elements and serve, for example, as a drive for test stands or other physical equipment (e.g. vacuum pumps, centrifuges, optical systems etc.). Gentle operation of the motors is achieved by the pulse amplitude modulation (PAM) used.

Specifically, the following motor types can be operated:

- Asynchronous motors (ASM)
- Brushless DC motors without sensors (BLDC)
- Brushless DC motors with sensors (BLDCS)

An integrated load compensation offers high speed constancy and - through low idling currents - avoids unnecessary heating up of the connected motors.

At the stop command, the connected motor is braked until it stops.

The control and monitoring of the inverter are performed by several microprocessors. This ensures high reliability and flexibility.

A firmware update can be performed on a PC via a serial interface (RS232); contact KaVo in this context.

The inverter can be completely remote-controlled. Various inputs and outputs are freely programmable.



# e@syDrive 4425, 4426.

## **A 1.5 Technische Daten Umrichter e@syDrive 4425**

Configuration	via the serial interface using a standard PCB browser
Operation	via an SPS-compatible remote control or using a standard PC browser (via the serial interface)
Display	lamps for operation (green) H4 and overload (yellow) H5
Dimensions	approx. 75 mm wide, 310 mm high, 215 mm deep, for switchgear housing see also B1.
Operating temperature	0 ... 40°C
Humidity of the air:	lower than 90 % relative humidity, non-condensating
Weight	approx. 3,0 kg
Tests and standards	VDE tested according to EN 61800-5-1 CSA to UL 508C EMV to EN 61800-3 EMC according to EN 61800-3
Ingress protection	IP20 according to DIN 40050

### **Power unit**

Electrical connection	single-phase max 50V~, 50/60 Hz or max 70 V- / 8 A
Current consumption	8A~
Output power	max. 350 VA continuous operation
Output voltage	3 * 45 V~ at 8 A
Output current	max. 8A~ per phase, continuous operation
Output frequency	30 ... 4000 Hz for ASM motors (240.000 min <sup>-1</sup> ) 30 ... 4000 Hz for BLDC motors (240.000 min <sup>-1</sup> )
Braking resistance	internal
Efficiency	93 % (at 250 VA, cos phi motor 86 %)

### **Motor sensors**

Motor temperature sensor	
PTC (cold conductor)	according to DIN 44081
Cold resistance	Rk < 550 Ohm
Tripping resistance (warm):	Ra >= 1350 Ω
Tripping temperature:	depending on PTC, 90...130°C
Operating voltage:	12V, via 4750 Ω pullup resistance
Recommended Type PTC:	Siemens+Matsushita M1100 B59100-M90-A70
Recommended Type KTY:	Semiconductor sensor KTY84, cut-out threshold configurable

Hall sensor connection, motor code:

Output voltage:	12V -10%
Output current:	max. 100mA
Signal level:	active low
Switching current:	Is = 15mA
Pullup resistance:	internal 3 time R = 2200 Ω

# e@syDrive 4425, 4426.

## Remote control

The function of the programmable inputs and outputs is described under Description of function A 4.4.

## Digital control inputs

FB\_IN1 ... 6 opto-decoupled,  $R_e = 10 \text{ k}\Omega$ , unwired=low  
X5:1 ... 6  $U_{\text{low}} = 0...+5 \text{ V}$ ,  $U_{\text{high}} = +13...+35 \text{ V}$ ,  $I_e = 2.4 \text{ mA}$  at 24 V  
Input protected up to max.  $\pm 35 \text{ V}$ , minimum pulse width 60 ms

FB-24 V X6:8 24V-supply voltage for the digital inputs

## Relay switching outputs

FB-Relais 1 Contact type: change-over contact, max. 250 V~, 1 A, max. 30 V-, 1 A  
X7:1 ... 3 min. switching current 1 mA at 24V (10mA bei 10V)

FB-Relais 2 Contact type: change-over contact, max. 250 V~, 1 A, max. 30 V-, 1 A  
X8:1 ... 3 min. switching current 1 mA at 24 V (10 mA at 10 V)

## Analogue inputs

FB-N value  $U_e = 0...10 \text{ V}$ ,  $R_e = 100 \text{ k}\Omega$ ,  $I_e = 0,1 \text{ mA}$  bei 10 V,  
X6:7 unwired 0 V, input protected up to max.  $\pm 40 \text{ V}$

FB+10 V  $U_{\text{out}} = 10 \text{ V} \pm 3\%$ ,  $I_{\text{out}} = \text{max. } 25 \text{ mA}$ ,  
X6 :6

FB-Masse Earth reference point for FB+10 V  
X6:5

FB-Input+ current input 0 ... 20 mA  
FB-Input- short-circuit-proof  $I_{\text{k}} = \text{max. } 50 \text{ mA}$   
X6:3,4

## Frequency output

FB-Out-Freq simple frequency output of the inverter, keying proportion 50 %  
X6:2 open collector,  $U_{\text{max}} = 24\text{V}$ ,  $I_{\text{max}} = 30 \text{ mA}$

FB-Ground Earth reference point for frequency-output  
X6:1

FB-voltage outputs are related to the frequency output FB Ground.  
The relay outputs are originally galvanically separated.\_

Supply module e@syDrive 4428

The mains adaptor is designed for supplies to the e@syDrive 4425.  
see GA Supply Module 4428 Mat. Nr. 1.003.1905

**i** *When using a transformer, or another power pack, the secondary voltage must be provided with insulation double that of the mains potential. This means the converter supply voltage must be galvanically separated from the mains.*

*When using a transformer the Standard EN 61558 for double insulation must be observed.  
Current: max. 16 A (4426, max. 10 A (4425).*

# e@syDrive 4425, 4426.

## A 1.5 Technical Data Inverter e@syDrive 4426

Configuration	via the serial interface using a standard PCB browser
Operation	via an SPS-compatible remote control or using a standard PC browser (via the serial interface)
Display	lamps for operation (green) H4 and overload (yellow) H5
Dimensions	approx. 75 mm wide, 337 mm high, 215 mm deep, for switchgear housing see also cap. B1.
Operating temperature	0 ... 40°C
Humidity of the air:	lower than 90 % relative humidity, non-condensating
Weight	approx. 3,0 kg
Tests and standards	VDE tested according to EN 61800-5-1 CSA to UL 508C EMV to EN 61800-3 EMC according to EN 61800-3
Ingress protection	IP20 according to DIN 40050

### Performance

Electrical connection	single-phase max 50 V~, 50/60 Hz or max 70 V- / 14 A
Current consumption	14 A~
Output power	max. 1000 VA continuous operation
Output voltage	3 x 45 V~ at 16 A
Output current	max. 16 A~ pro Phase continuous operation
Output frequency	30 ... 4000 Hz for ASM-motors (240.000 min <sup>-1</sup> ) 30 ... 4000 Hz for BLDC-motors (240.000 min <sup>-1</sup> )
Braking resistance	internal
Efficiency	93 % (at 1000 VA, cos phi motor 86 %)

### Motor sensors

Motor temperature sensor	
PTC (cold conductor):	according to DIN 44081
cold resistance:	Rk < 550 Ohm
Tripping resistance (warm):	Ra >= 1350 Ω
Tripping temperature:	depending on PTC 90...130°C
Operating voltage:	12 V, via 4750 Ω pullup resistance
Recommended Type PTC:	Siemens+Matsushita M1100 B59100-M90-A70
Recommended Type KTY:	Semiconductor sensor KTY84, cut-out threshold configurable

Hall sensor connection, motor code:

Output voltage:	12 V -10%
Output current:	max. 100 mA
Signal level:	active low
Switching current:	I <sub>s</sub> = 15 mA
pullup -resistance:	internal 3 x R = 2200 Ω

# e@syDrive 4425, 4426.

## Remote control

The function of the programmable inputs and outputs is described under Description of function A 4.4.

## Digital control inputs

FB-In1 ... 6                    24 V-SPS compatibly  
X5:1 ... 6                    U\_low = 0...+5 V, U\_high = +13...+35V, I<sub>e</sub> = 2 mA bei 24 V  
Input protected up to max. ± 35 V, minimum pulse width 60 ms

FB-24V X6:8                    24V- supply voltage for the digital inputs

## Relay switching outputs

FB-Relais 1                    Contact type: change-over contact, max. 250 V~, 1A, max. 30 V-, 1 A  
X7:1 ... 3                    min. switching current 1 mA bei 24 V (10 mA bei 10 V)

FB-Relais 2                    Contact type: change-over contact, max. 250 V~, 1A, max. 30 V-, 1 A  
X8:1 ... 3                    min. switching current 1 mA bei 24 V (10 mA bei 10 V)

## Analogue inputs

FB-N\_soll  
X6:7                    U<sub>e</sub> = 0...10 V, R<sub>e</sub> = 100 kΩ, I<sub>e</sub> = 0,1mA bei 10 V,  
unwired 0 V, Input protected up to max. ± 40 V

FB+10V  
X6 :6                    U<sub>out</sub> = 10 V +-3%, I<sub>out</sub> = max. 25 mA,

FB-value  
X6:5                    Earth reference point for FB+10 V

FB-Input+  
FB-Input-  
X6:3,4                    current input 0 ... 20 mA  
short-circuit-proof I<sub>k</sub> = max. 50 mA

## Frequency output

FB-Out-Freq  
X6:2                    simple frequency output of the inverter, keying proportion 50 %  
open collector, U<sub>max</sub> = 24 V, I<sub>max</sub> = 30 mA

FB-ground  
X6:1                    Earth reference point for frequency-output

FB-voltage outputs are related to the frequency output FB Ground.  
The relay outputs are originally galvanically separated.

Supply module e@syDrive 4429

The mains adaptor is designed for supplies to the e@syDrive 4426.  
see GA Supply Module 4428 Mat. Nr. 1.003.1905

**i** *When using a transformer, or another power pack, the secondary voltage must be provided with insulation double that of the mains potential. This means the converter supply voltage must be galvanically separated from the mains.*

*When using a transformer the Standard EN 61558 for double insulation must be observed.muss.*  
*Current: max. 16 A (4426, max. 10 A (4425).*

# e@syDrive 4425, 4426.

## A 2 Scope of delivery - Accessories

### A 2.1 Scope of delivery

- Frequency inverter type 4425 Mat.-No. 1.001.2769 (open version ) or
- Frequency inverter type 4426 Mat.-No. 1.002.2514 (open version )  
or
- Frequency inverter type 4425 Mat.-No. 1.001.2768 (closed version) or
- Frequency inverter type 4426 Mat.-No. 1.002.2513 (closed version)
  
- Instructions for use and assembly Mat.-No. 1.001.7140
- Brief Operating Instructions Mat.-No. 1.003.1414

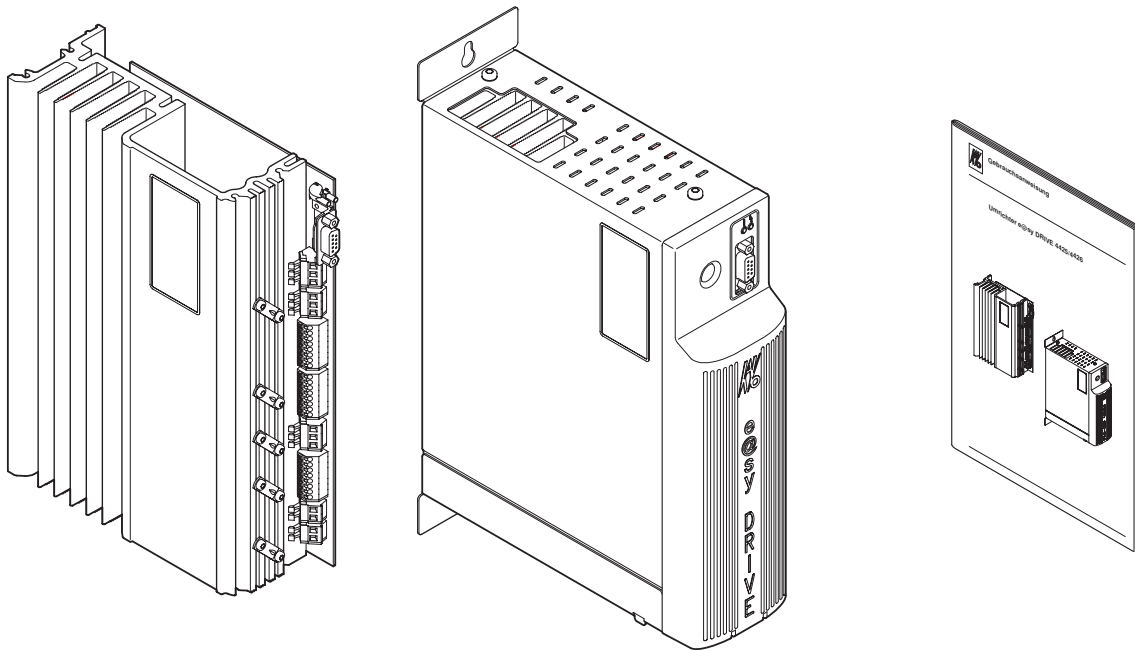

### A 2.2 Accessories

- Connection adapter for 9 pin Sub-D plug with screw connection with PC Mat. No. 1.002.2025.
  
- -Power modul for Frequenz-Inverter Ttyp 4428 Mat. No. 1.001.2770 (closed version)
- -Power modul for Frequenz-Inverter typ 4429 Mat. No. 1.002.2515 (closed version)
- -Installation Assistant for 9-polar connection cable Mat. No. CD 1.003.2701
- -Brief Operating Instructions Mat. No. 1.003.1414

# e@syDrive 4425, 4426.

## A 3 Operational elements

H4 LED ① Operational (green)

H5 LED ② Fault (yellow)

Operation of the unit is usually carried using an SPS-compatible remote control

The unit is configured exclusively by the special software using a standard Web browser and by means of a serial data connection (standard 9 polar sub-D cable) which communicates with the Inverters 4425/4426.

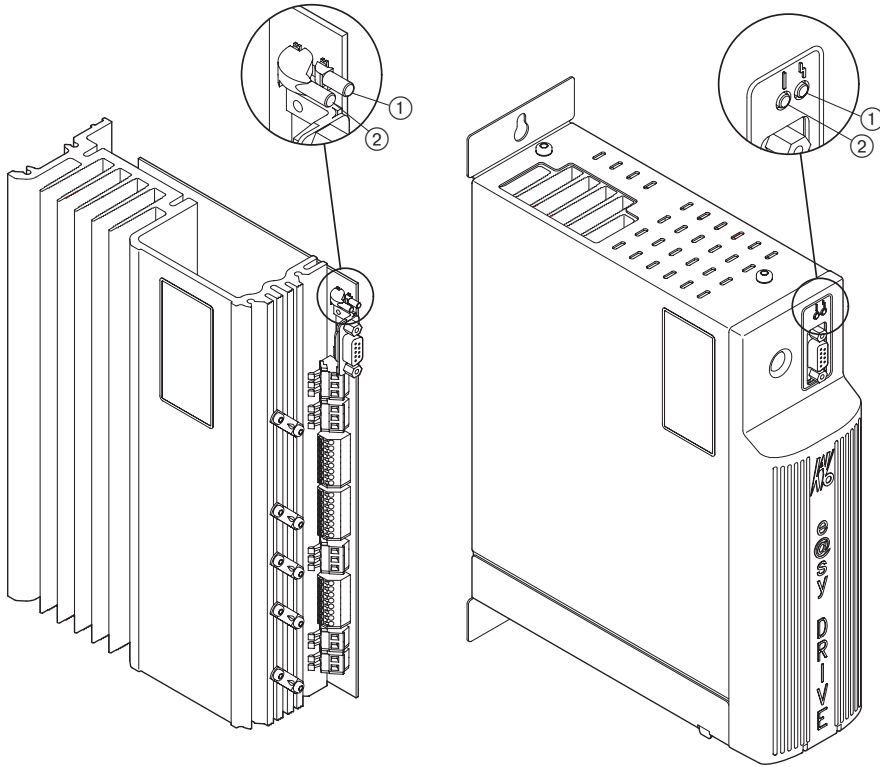

### A 3.1 Rating plate ③

The unit is in conformity with the requirements of the European VDE Standard.

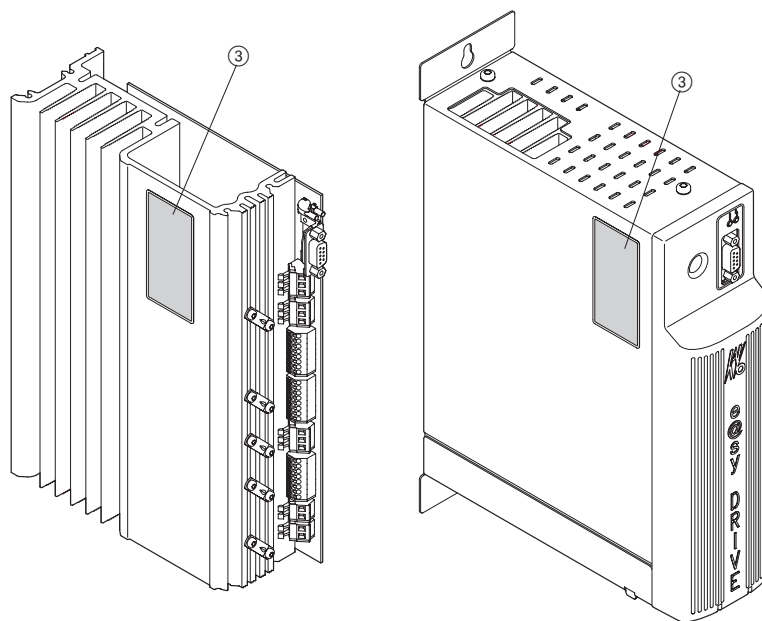

## A 4 Description of function

The min. output frequency is 30 Hz (1800 min<sup>-1</sup>)

The max. output frequency is 4000 Hz (240 000 min<sup>-1</sup>) for ASM-motors and for DC-motors.

The max. output power is 350 VA.(4425) and 1000 VA (4426).

The frequency inverter Typ 4425/4426 is suitable for the variable-frequency control of various motors, especially with high frequencies of up to 4000 Hz corresponding 240 000 min<sup>-1</sup>. The output voltage is set via a pulse amplitude modulation (PAM) with 120° blocks.

### A 4.1 Three-phase asynchronous motor (ASM)

Three-phase asynchronous motors (ASM) are controlled by means of pulse amplitude modulation (PAM). The voltage/frequency table serves as a basis for determining the motor voltage. Various control procedures are available – controlling method IR and load compensation are provided.

### A 4.2 Brushless DC motor without sensors (BLDC)

Brushless DC motors have a permanent magnet rotor and a fixed three-phase winding. The winding is preferably designed as an air-gap winding with yoke, but a grooved version similar to an ASM motor is also possible. The motor is controlled as a function of the rotor position. The rotor position is simulated by the inverter by measuring the e.m.f. voltage from the three part-windings. No position sensors are required. In order to permit measurement of the e.m.f. voltage, the motor inductance may not be too large.

### A 4.3 Brushless DC motor with position sensors (BLDCS)

The design of this motor is identical to that of the BLDC motor described above. For position detection, however, 3 additional Hall sensors are installed in the motor.

### A 4.4 Remote control

The voltages at the remote control plug may be max. 60 V DC or. 25V AC according to SELV (EN50178) betrag. Exceptions are the relay connections, which are approved for max. 250 V AC.

All connections are potentially isolated from the control and with respect to the protective conductor.

The remote control provides a large number of programmable inputs and outputs:

6 digital inputs

SPS-compatible (24 V). The inputs In1 ... 6 are programmable with the parameters P110-input IN1 ... P115-input IN6 (see Section A 4.5)

2 relay outputs

(potential-free max. 250 V~, 30 V- / 1 A) for outputting various status signals (see parameters P120-Relais REL1 ... P121-Relais REL2)

2 analogue inputs

FB-N\_soll (0 ... 10V) or FB-Input+, FB-Input- (0...20 mA) for the functions of speed setpoint default and torque default. The programming is performed with the parameters P129-quell-AIN (see Section A 4.6)

1 frequency output

(open collector, max 24 V) with one times the inverter output frequency.

2 auxiliary voltages

+24 V (max. 100 mA) for wiring of the digital inputs In1...In6 and of the relay outputs REL1...REL2

+10 V (max. 25 mA) as auxiliary supply from external potentiometers to the analogue inputs AIN1 and AIN2

# e@syDrive 4425, 4426.

Control with external voltage supply

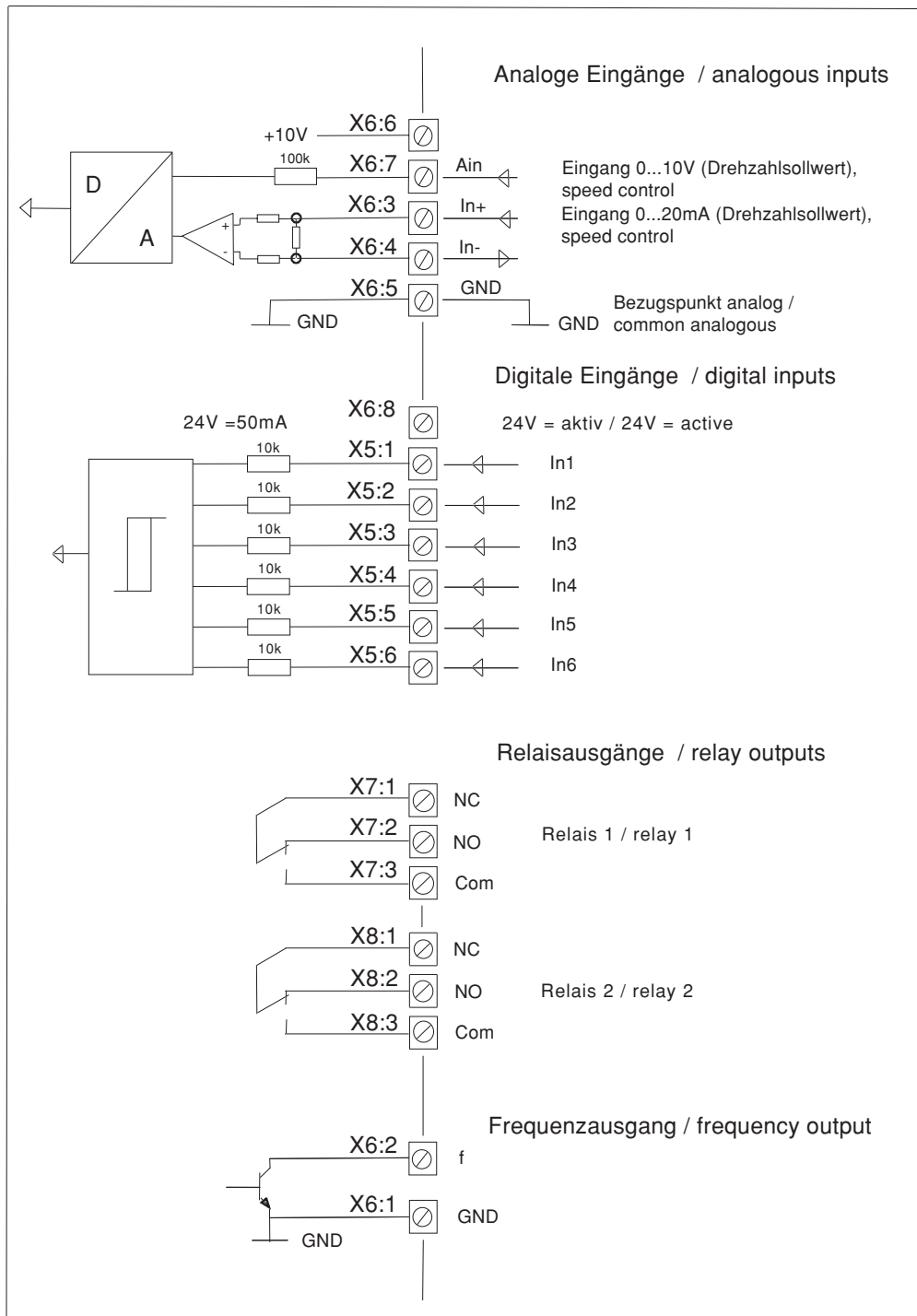



# e@syDrive 4425, 4426.

Control without external voltage supply

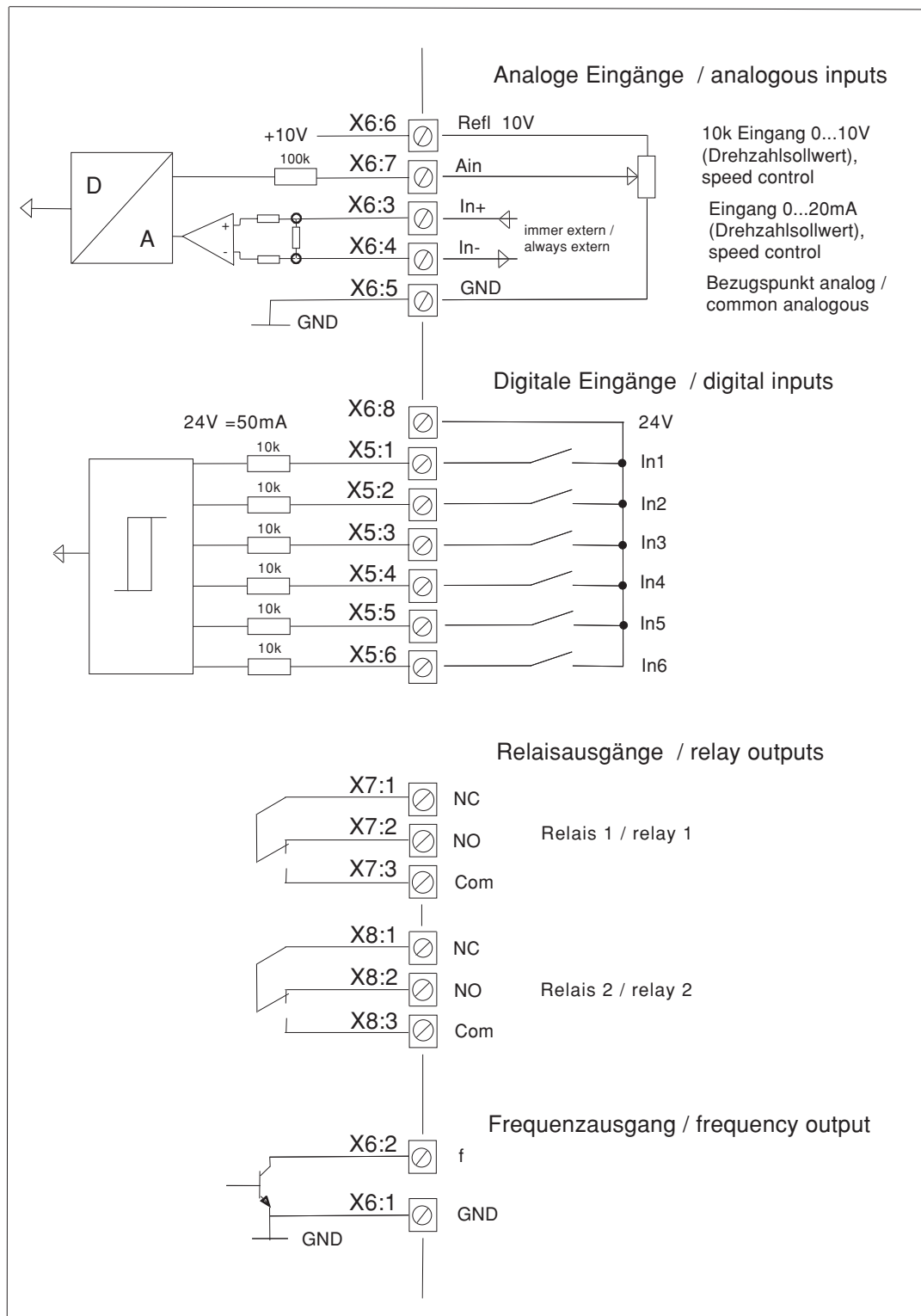

# e@syDrive 4425, 4426.

## A 4.5 Motor codes via inputs IN2...IN6 to X5:

In order to use IN2...IN6 for the motor codes, code P102 must be assigned to the number of the motor to be used (1...32). Additionally, the required inputs are to be set to motor code with parameters P111 – input IN2 up to P115 – input IN6.

Bit4 IN2	Bit3 IN6	Bit2 IN5	Bit1 IN4	Bit0 N3	code value in P20	Assigned motor parameter memory
L	L	L	L	L	1	M1
L	L	L	L	H	2	M2
L	L	L	H	L	3	M3
L	L	L	H	H	4	M4
L	L	H	L	L	5	M5
L	L	H	L	H	6	M6
L	L	H	H	L	7	M7
L	L	H	H	H	8	M8
L	H	L	L	L	9	M9
L	H	L	L	H	10	M10
L	H	L	H	L	11	M11
L	H	L	H	H	12	M12
L	H	H	L	L	13	M13
L	H	H	L	H	14	M14
L	H	H	H	L	15	M15
L	H	H	H	H	16	M16
H	L	L	L	L	17	M17
H	L	L	L	H	18	M18
H	L	L	H	L	19	M19
H	L	L	H	H	20	M20
H	L	H	L	L	21	M21
H	L	H	L	H	22	M22
H	L	H	H	L	23	M23
H	L	H	H	H	24	M24
H	H	L	L	L	25	M25
H	H	L	L	H	26	M26
H	H	L	H	L	27	M27
H	H	L	H	H	28	M28
H	H	H	L	L	29	M29
H	H	H	L	H	30	M30
H	H	H	H	L	31	M31
H	H	H	H	H	32	M32

L = low voltage 0..5V (contact open), H = high voltage, 24 V (contact closed)

## A 4.6 Setpoint value selection

The frequency setpoint value (speed setpoint value) can be predetermined by various sources, and the mode of operation is shown in the following figure.

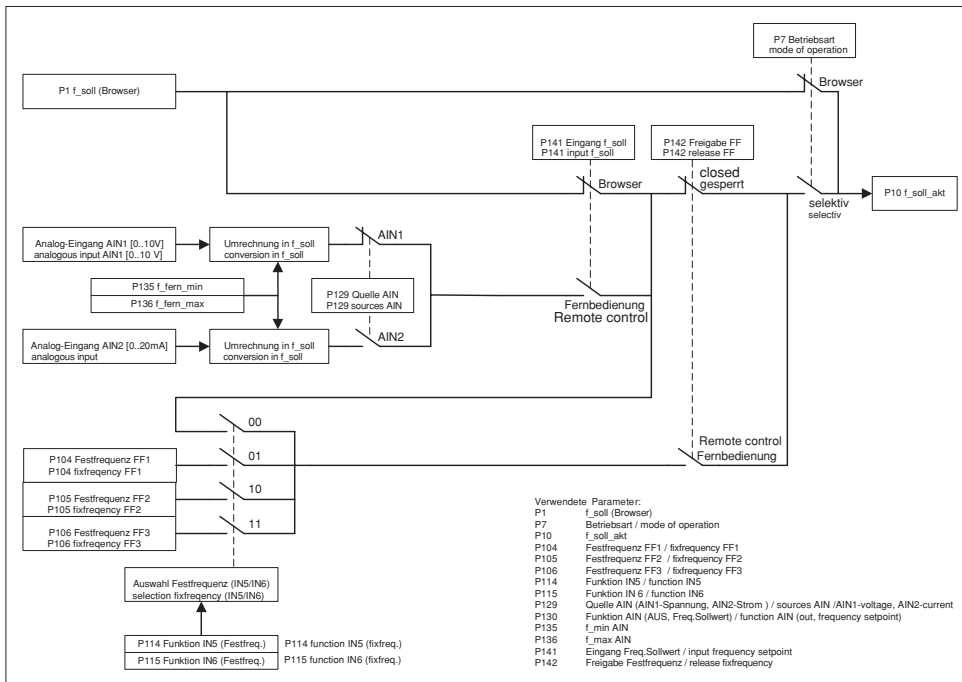

picture: setpoint value selection

In order to use the setpoint value of the browser in P1-f\_value, the browser is set to P7-Drive. This enables the functions start/stop and assigned frequency to be controlled via the browser.

**i** Following a power failure, an automatic start by the installed start signal at IN1 is prevented. A flank at the start entry is necessary.

**!** When starting via the browser, FB IN1 (P110) must be placed at On

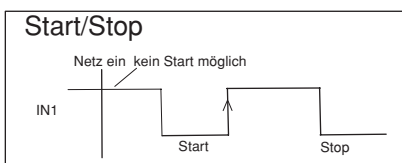

Alternatively, you can adjust P7-Drive to "selective"; P141-Input.f value to "browser"; and P142-Release FF to "blocked".

# e@syDrive 4425, 4426.

In order to use the setpoint value from analogue input AIN1 or AIN2, set P7-Drive to “selective”; P141-Input f value to “remote control” ; P142-Release FF to “blocked” ; and P129 to the desired analogue input. The scale of the analogue inputs is carried out via “P135-f\_fern\_min” and “P136-f\_fern\_max”.

To use the fixed value (fixed frequency) in P104 to P106, set P7-Drive to “selective”, as well as P142-Release FF to “remote control”. Selection is effected from control inputs IN5 and IN6. If both inputs are on OV, then the setpoint value from P1 – f value or from analogue input AIN1/AIN2 is used – depending on the condition of P141-Input.f value. This allows the use of up to four fixed frequencies. The following table illustrates the assignment of the input combinations.

input IN5	input IN6	active setpoint value
L	L	P1-f_soll oder AIN1 (1)
L	H	P104-FestfreqFF1
H	L	P105-FestfreqFF2
H	H	P106-FestfreqFF3

L = low voltage (0V), H = high voltage (24V)

Note (1): with this combination the setpoint value in P141-Input. f is selected, i.e. P1- f value or from analogue input AIN1 or AIN2 (dependent on P129).

## A 4.7 Emergency motor stop at Power failure

With parameter P58-emerg.stop, the inverter can be set so that a running motor is automatically braked in the event of failure or if the mains voltage falls below ones threshold value. The inverter supplies itself from the motor voltage still present, and braking is performed with maximum power of the brake resistance. The motor generally cannot be braked to a stop since the motor voltage is no longer sufficient for supplying the inverter. If an emergency stop occurs as a result of a brief drop in mains voltage, the motor is braked to a stop. In order to start the motor again, the operator must first input a stop command followed by a start command.

## A 4.8 Counterclockwise operation

In standard operation, the motor, spindel operates clockwise. With one of the parameters P111-input IN2 to P113-input IN4, a digital input can be configured for counterclockwise operation. If the corresponding input is supplied with voltage, the direction of rotation changes to counterclockwise. If the direction of rotation is switched while the motor is running, the motor is first braked before it is powered up again in the altered direction of rotation.

## A 4.9 Wiring diagram

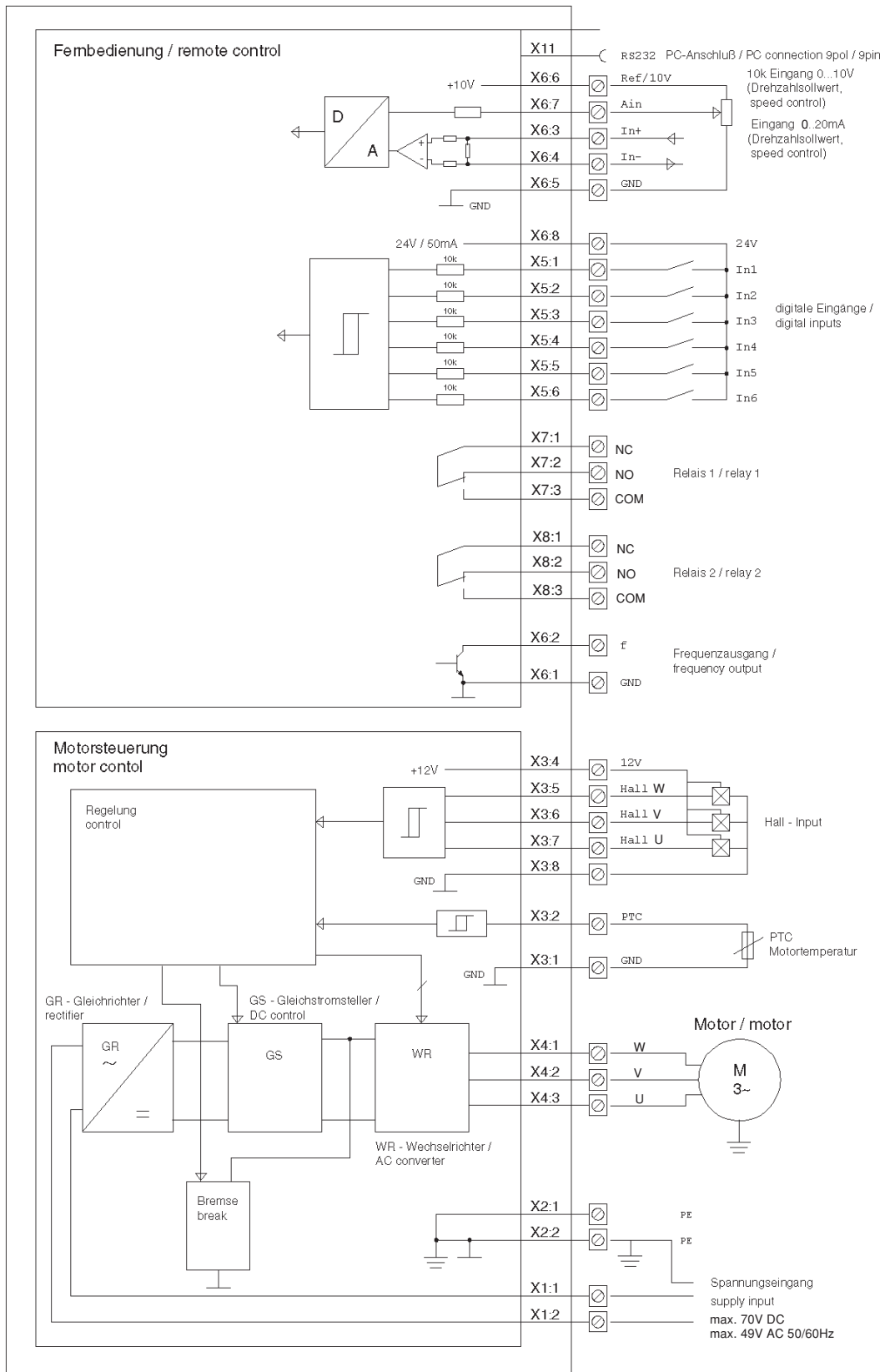

# e@syDrive 4425, 4426.

## B 1 Assembly and Installation

 Before the installation and commissioning of this device, please read the safety and warning information under Section A1 carefully.

### B 1.1 Assembly

Frequency inverter type 4425, 4426 designed for mounting in cabinet:  
Use 4 screws for mounting on switch board.  
Ensure proper electrical connection to protective conductor.

### Information on cooling

 The inverter is cooled by an integral fan. To ensure effective cooling, at least the following clearances must be maintained around the inverter:

End surfaces: 50 mm

Longitudinal: 10 mm

### Installation frequency inverter e@syDrive 4425

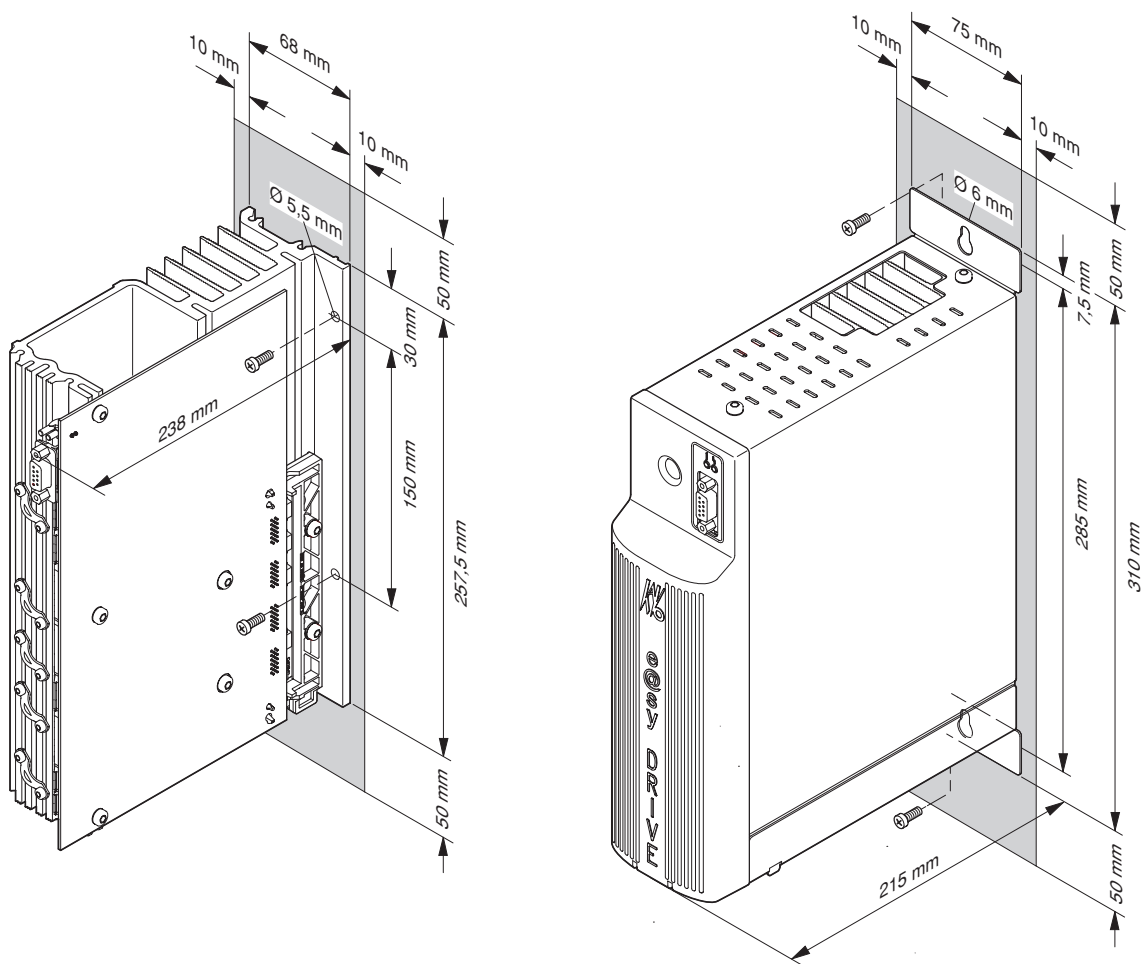

# e@syDrive 4425, 4426.

## Installation frequency inverter e@syDrive 4426

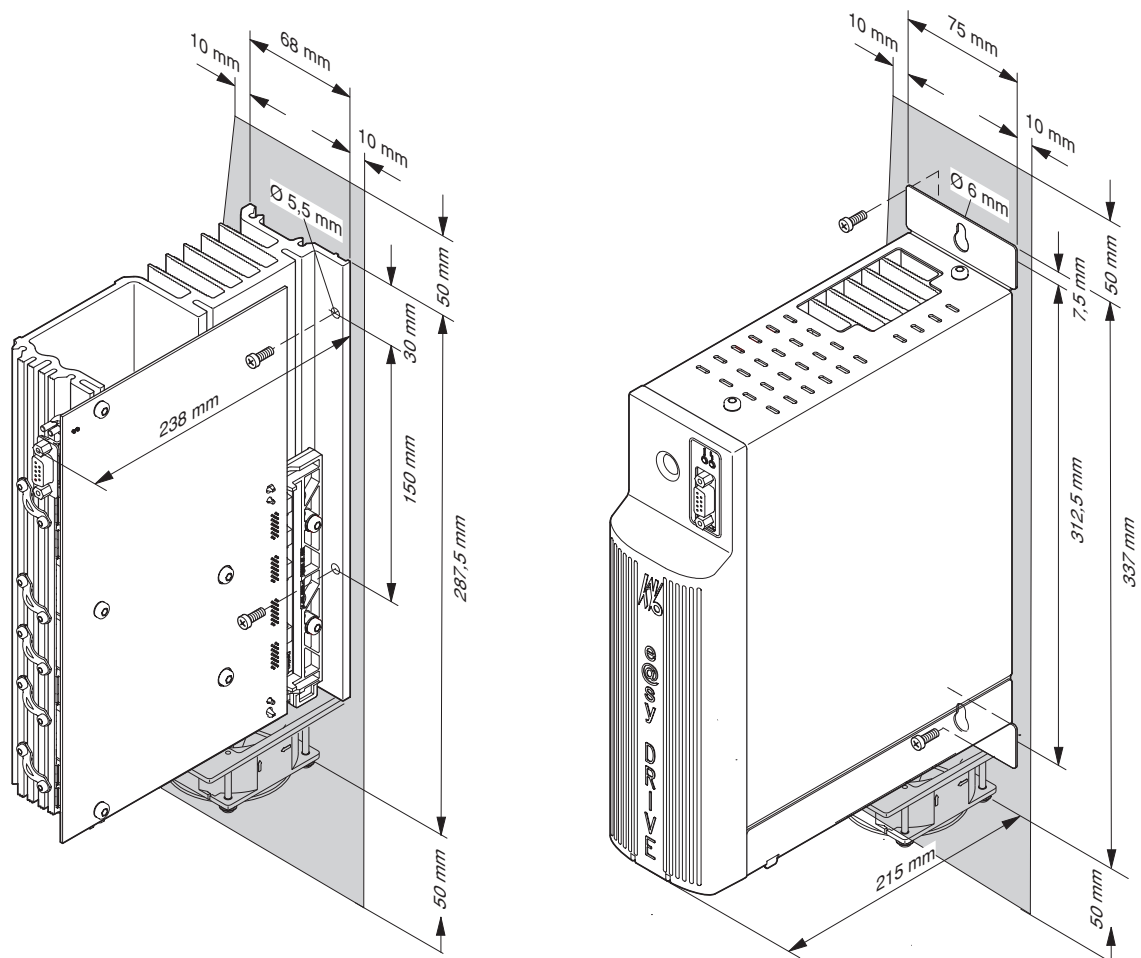

### B 1.2 Electrical Installation

**⚠** When installing the inverter, the applicable safety regulations must be observed. Cut-out devices for preventing unexpected start-up must be provided. A device for the electrical isolation of the inverter must be provided unless a mains cable with a plug is used. The Power modul must be provided with 16 A power cut-outs with tripping characteristic B.

### B 1.3 Wiring guidelines for compliance with the EMC standards

The inverter was tested according to EMC product standard EN 61800-3 (variable-speed electrical drives).



■ The above-mentioned EMC product standard can be complied with only by means of shielded motor and control cables. It should be ensured that the cable shields rest over a large area of the inverter housing and are surrounded by the cable clips. A shielded mains cable is not required.

■ The control cables must be laid separately from (not parallel with) mains and motor cables. Shielded cables and metallized plug housings should be used.

■ All devices in the mounting cabinet should be connected over a large area to a common earthing point via short earthing cables.

■ On installation of the inverter, valid safety provisions may on no account be infringed.

# e@syDrive 4425, 4426.

## B 1.4 Electrical connections

Access to the electrical connections  
Connection area for e@syDrive 4425, 4426

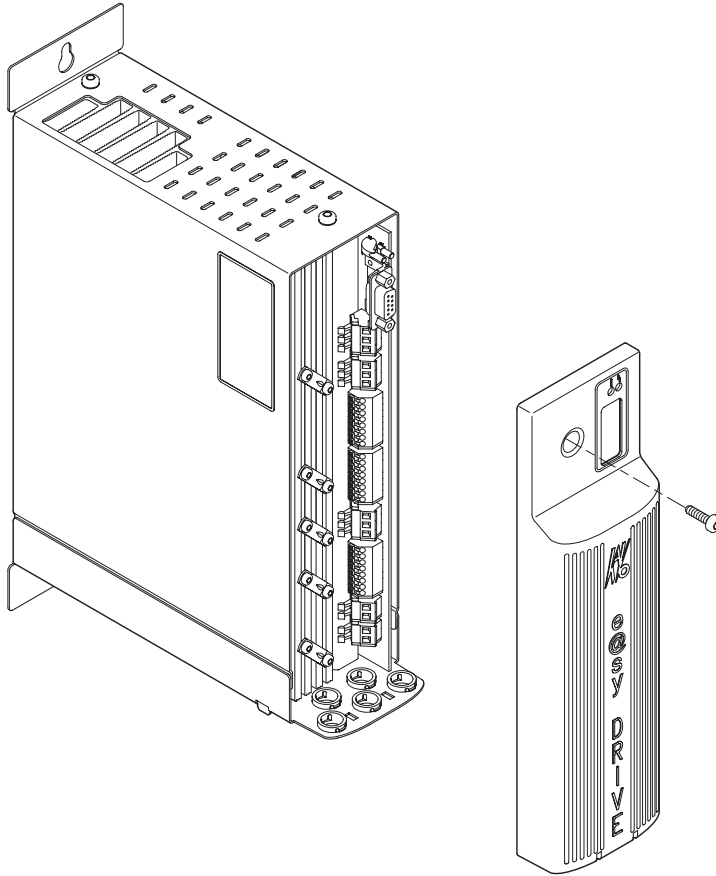

**i** For inverter 4425, 4426 the supply cable is connected to "In sek." ② and "PE" ①. The cable shield is to be neatly clamped under the traction relief.  
When the closed-cover version is selected, ensure that both covers are conductively well connected together (either via the switchbox or other appropriate means).

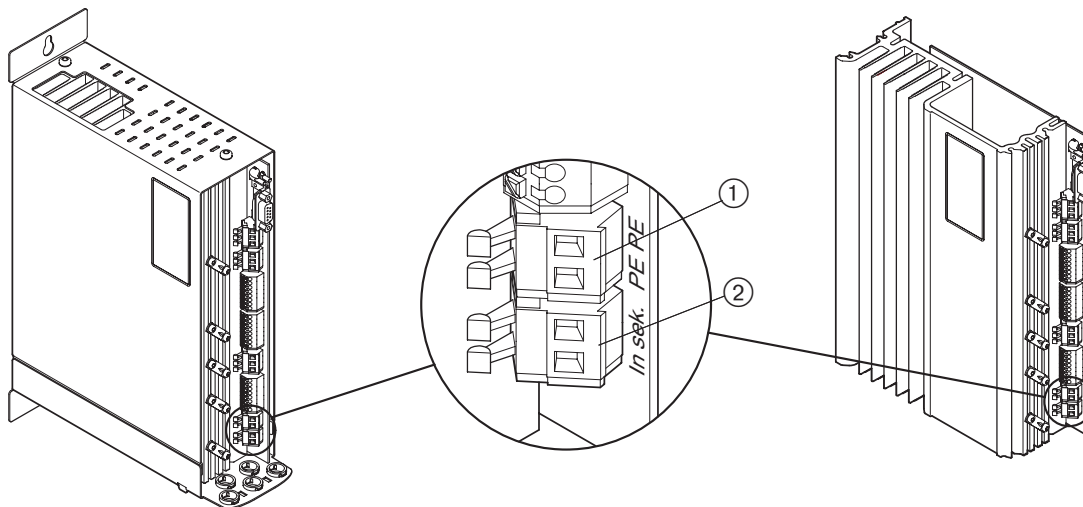



# e@syDrive 4425, 4426.

## Motor connections

The motor is connected to U,V,W ①.

It is possible to connect vibration sensors to "Hall 1,2, 3" ④, and their electrical supply to "12V" or "GND" ③.

A motor-temperature sensor is attached to "PTC" and "GND" ②.

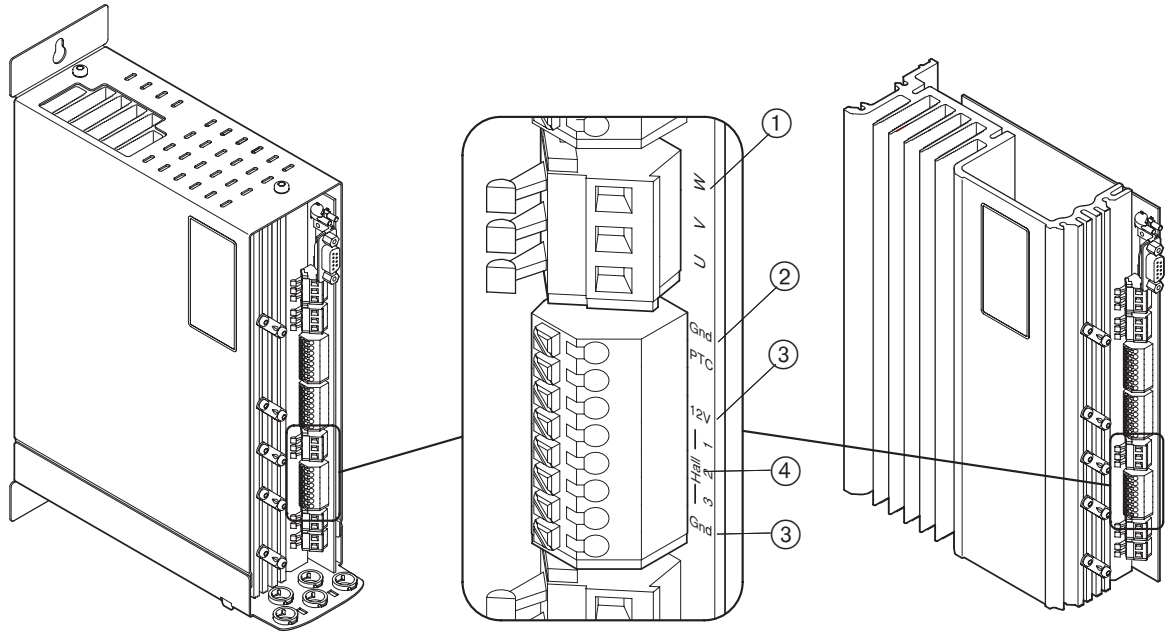

plug type: spring-clip (max 2,5 mm<sup>2</sup> / AWG 12)

## X4: Connection Remote control

connection of digital outputs (Relays)

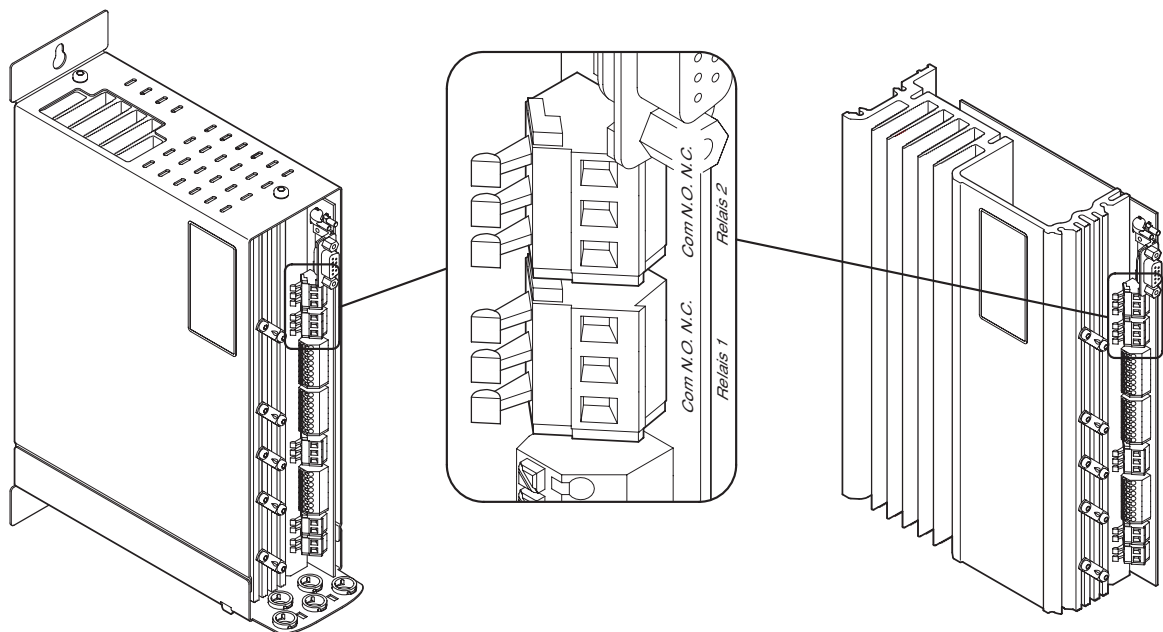

# e@syDrive 4425, 4426.

connection of digital inputs, analogue inputs and frequency outputs

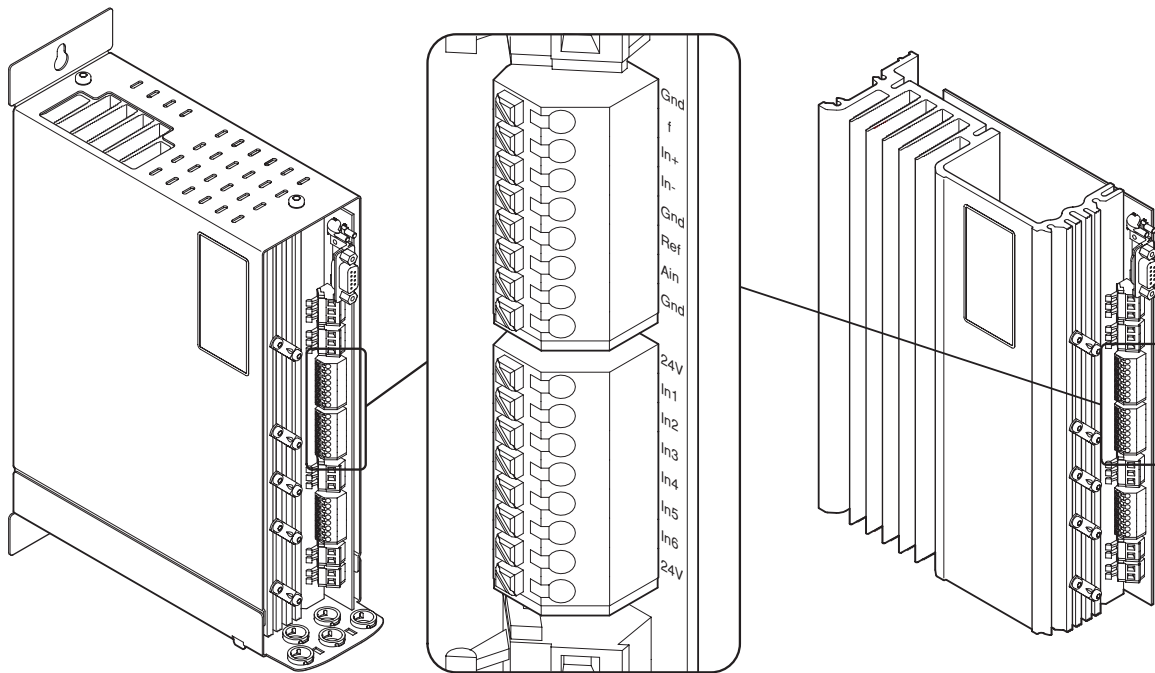

## X5: connection PC for configuration

Plug type: 9-pin socket Sub-D ①, Circuit Mat.- Nr. 1.002.2025 Installation assistant see A 2.2 Accessories

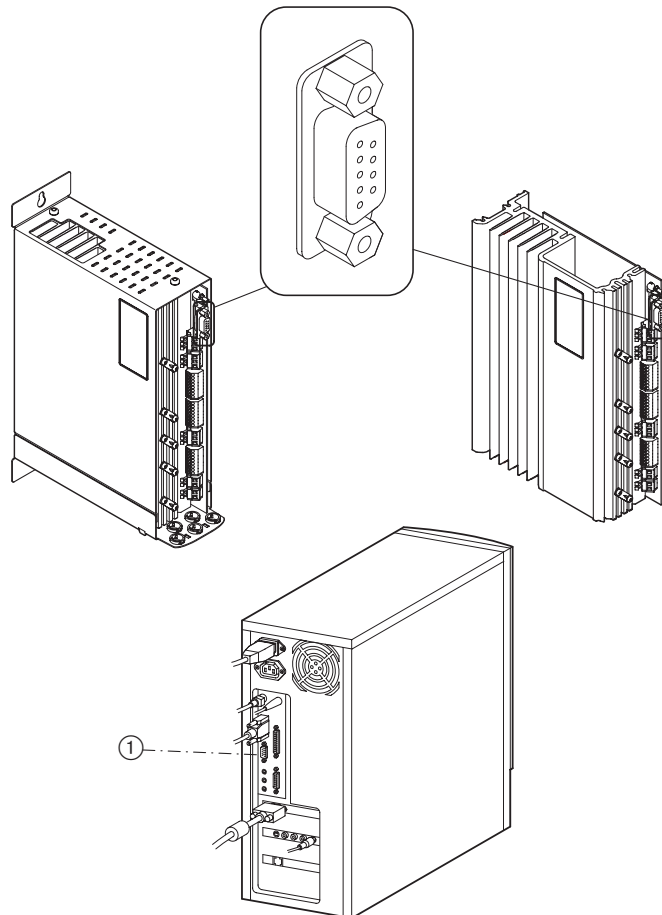

# e@syDrive 4425, 4426.

## B 2 Description of the Installation Assistant e@syDrive 4425/4426

Apart from the two LED's H4 Operation and H5 Fault, the inverter contains neither operating nor display elements. The complete operation and configuration is regulated with the help of a standard Microsoft Windows PC Web-browser (e.g. Microsoft Internet Explorer or Netscape Navigator). The browser communicates serially with the inverter 4425/4426 via a so-called data transmission network, using a serial cable connected to the inverter. The contents of the configuration-software is stored in the inverter itself, and after selection of the IP identification address in the browser, this is then loaded and started.

The installation assistant provides all necessary pre-requisites for the programme to automatically instal this data transmission connection.

The whole procedure is carried out automatically and installs the KaVo 4425/4426 icon on the desktop. A double-click on this icon activates the installation software, and starts the connection to the data transmission network (see Tasks of the Installation Assistant).

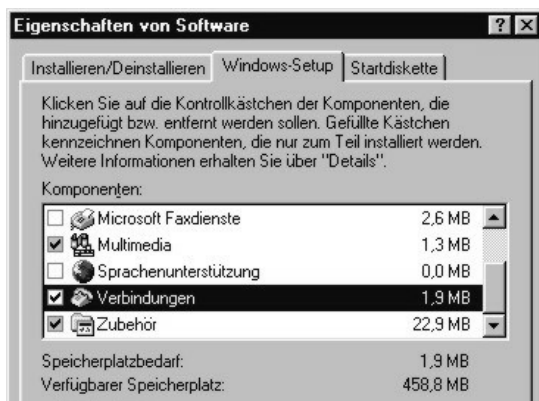

In the following chapters, the tasks of the Installation Assistant; the features of the individual operating systems; (Win 95, Win 98, 2000, ME, NT, XP) and their applications are explained.

Connecting the Inverter 4425/4426 with the serial interface (COM interface) of the PC

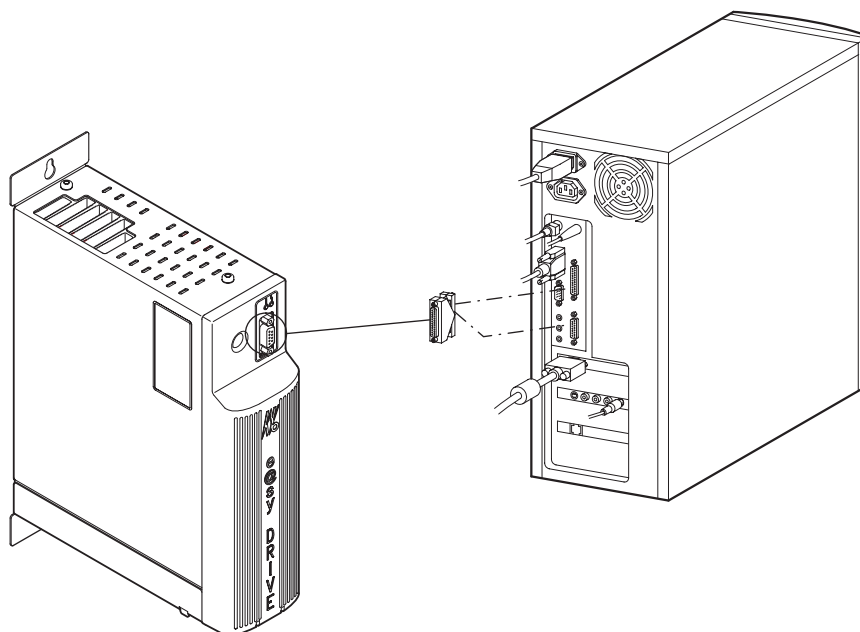

## B 2.1 Tasks of the Installation Assistant

### Recognition of the installed drive system

When implementing of the programme, the drive system being used is first established. Recognition of the drive system is necessary in order to access the special properties of the respective system in order to appropriately control the further course of the programme.

### Recognition of the standard browser

Configuration of the e@syDrive is carried out with the help of a Web browser and a supplementary programme (Java-Applets).

Therefore it is essential that the installed browser is at a specific development status. For this reason, the Installation Assistant investigates the installed browser and indicates if it does not meet the requirements.

### Discovering if the data transmission background is correctly installed

In order to provide a data transmission connection, the transmission background must be installed. The programme set-up checks if the transmission background is available. If this is not the case, the user receives a fault warning. At the same time a Windows set-up is automatically started, whereby the user can install the necessary components.

### Recognition of the RAS-Version (Remote Access Service)

For an automatic set-up of the data transmission connection, specific Windows functions (WIN-API) are used. As these are not available on older Windows versions, the installed RAS-Version is checked and, if necessary, an update is automatically started.

### Installation of the connection software

In order to access the e@syDrive, the software for the connection is installed via a serial cable connection (COM interface).

### Setting up the data transmission connection

The data transmission connection for the configuration of the e@syDrive via the serial interface is set up automatically. Furthermore, other adjustments specific to e@syDrive for this connection occur (no flow-control, connection rate 38400bps, IP-Address 10.0.0.1, no IP-header condensing)

### Installation of an icon on the desktop and in the Start menu

On completion of the installation, an icon is installed on the desktop and in the Start menu. This icon indicates a programme with which the data transmission connection is automatically started, and the standard browser with the address details [http:// 10.0.0.1](http://10.0.0.1) is called up.



*The Internet browser used (Microsoft Internet Explorer) must be correctly configured so that the so-called Java-Applets can be processed: Microsoft VM (virtual machine) must be activated, not SunVM!*

## B 2.2 Installing the Installation Assistant in various operating systems

### Windows 95

With Windows 95 the minimum requirement is the version Windows 95B. The basic installation of Windows 95B must at least include Internet Explorer 4.01.

 *If this is not available, inform your IT specialist!*

Furthermore, an update of the RAS software must be carried out. This update is started automatically by the Installation Assistant.

The standard installation of Windows95B does not include the data transmission network, which must eventually be installed. In this case, Windows Setup is automatically started by the setup programme.

In addition, a driver for the serial connecting cable is not included as standard.

This will be prepared and installed by the setup programme.

After inserting the CD "Installation Assistant" the following messages appear on the screen:

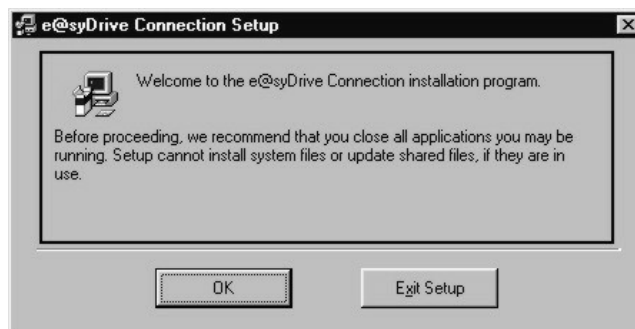

- confirm with "OK"

### Installation of the data transmission network

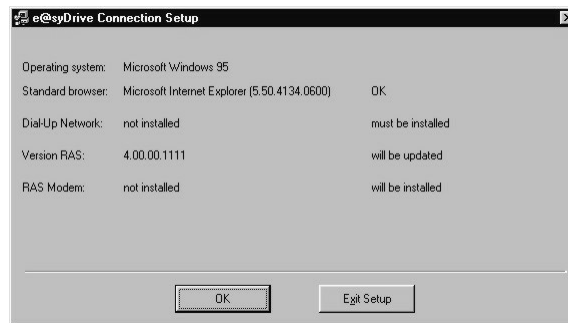

- confirm with "OK"

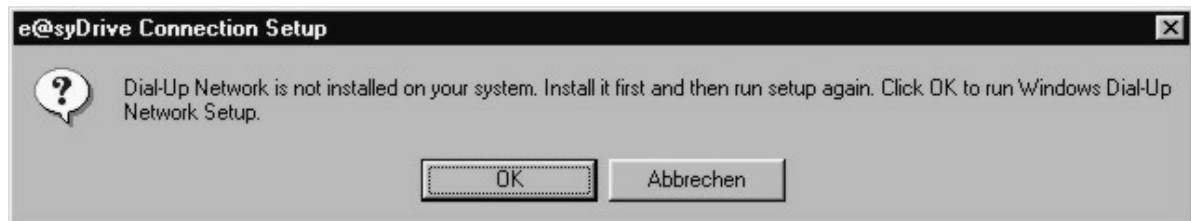

- confirm with "OK"

# e@syDrive 4425, 4426.

At "connections", if the background is grey, double-click on "connections" until the background turns white.

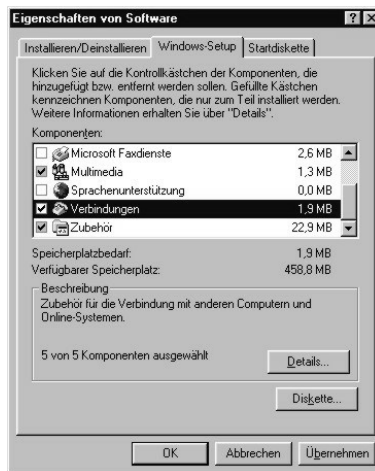

- confirm with "OK"

- several installations are carried out, all of which must be confirmed with "yes".
- finally, restart the computer.
- open the CD compartment and close it again.

## Update of the RAS software being carried out

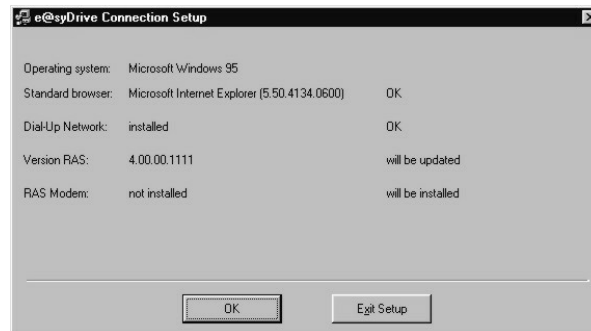

- confirm with "OK"

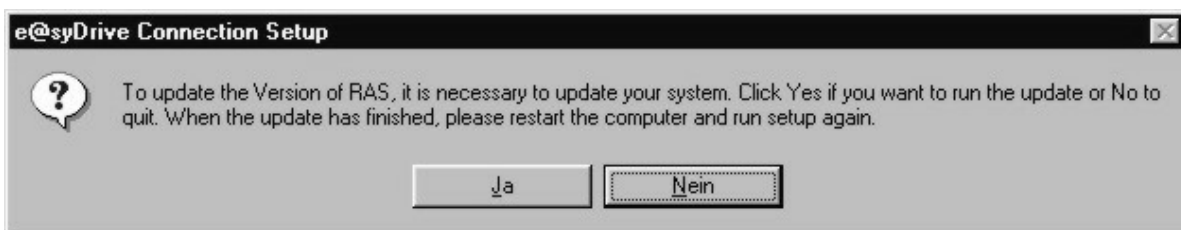

- confirm restart with "yes"
- open the CD compartment and close it again.
- confirm everything up to this window with "OK"

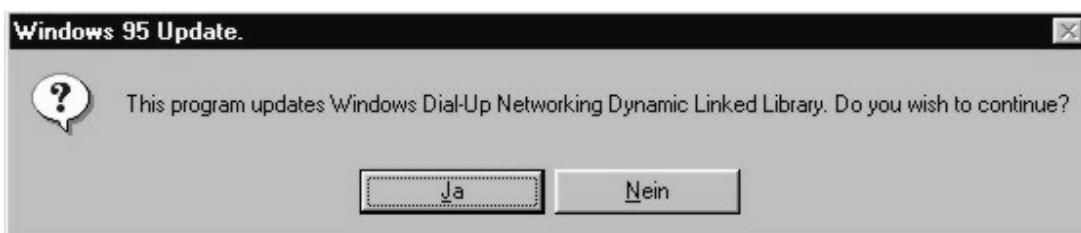

- confirm restart with "yes"

# e@syDrive 4425, 4426.

## RAS update being carried out

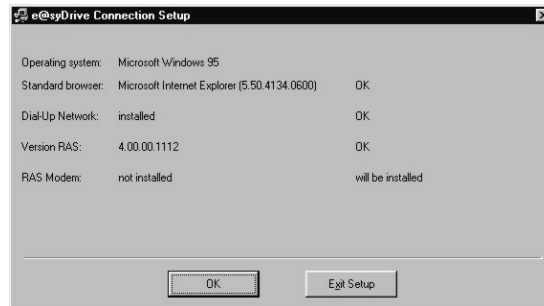

- confirm with "OK"

## select location of serial connecting cable

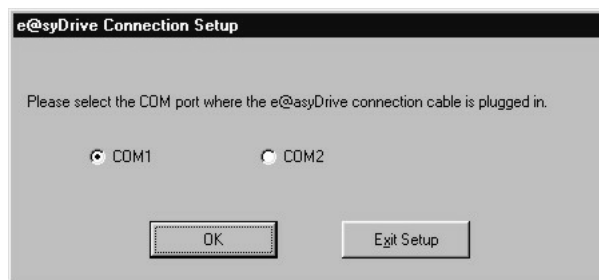

- confirm with "OK"

RAS modem installed



- confirm with "OK"



- confirm with "OK"



- confirm "Reboot"

After successful installation, the "e@syDrive" icon appears on the desktop



# e@syDrive 4425, 4426.

## Windows 98 / 2nd Edition

With Windows 98 normally no update is necessary, i.e. no new Internet Explorer has to be installed and it is also not necessary to perform an RAS update.

The standard installation of Windows98 does not include the data transmission network, which must eventually be installed. In this case, Windows Setup is automatically started by the setup programme.

The modem driver will be prepared and installed by the setup programme.

After inserting the CD "Installation Assistant" the following messages appear on the screen:

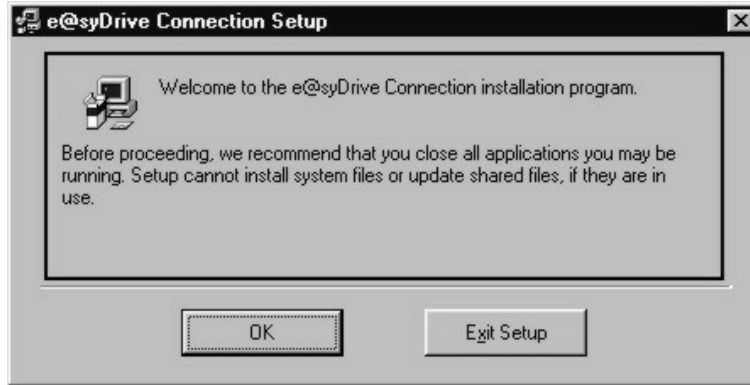

- confirm with "OK"

Installation of the data transmission network

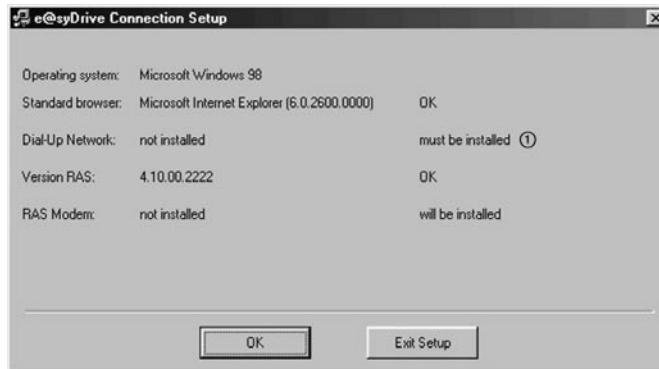

- confirm with "OK"

- ① This message appears only when in Windows 98 properties "connections" has not been clicked. (for installation of "connections" - see under Win 95)

- when "connections" installed, please restart

this message appears:

RAS update being carried out

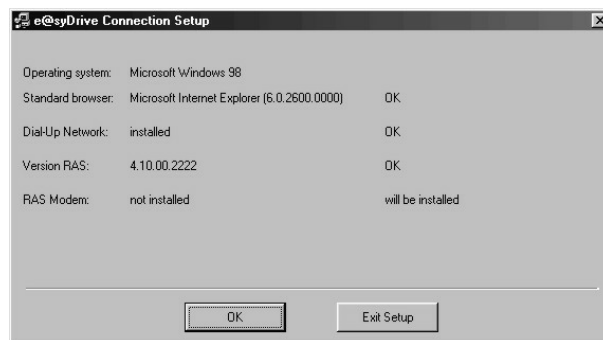

- confirm with "OK"

select location of serial connecting cable



## e@syDrive 4425, 4426.

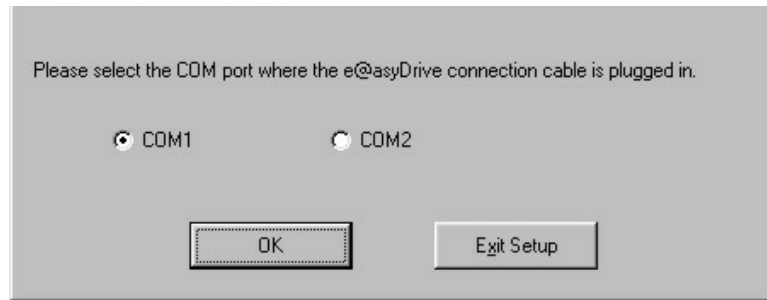

- confirm with "OK"

RAS modem installed



- confirm with "OK"

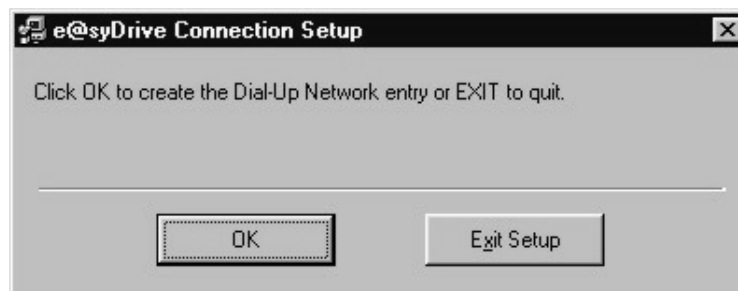

- confirm with "OK"



- confirm "Reboot"

After successful installation, the "e@syDrive" icon appears on the desktop



# e@syDrive 4425, 4426.

## Windows 2000

Windows 2000 needs no software update. For the installation of the modem a special Windows 2000 driver is used. An automatic start for the data transmission connection follows with the programme rasdial.exe.

After inserting the CD "Installation Assistant" the following messages appear on the screen:

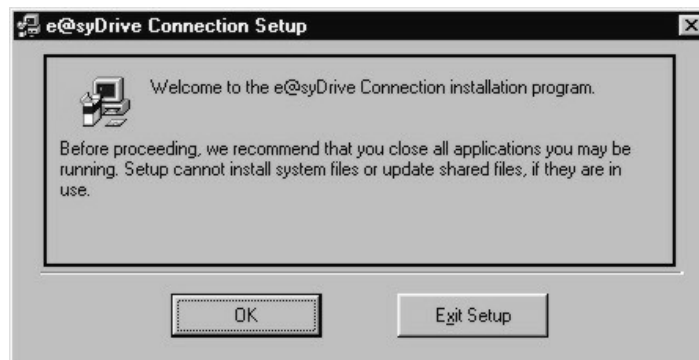

- confirm with "OK"

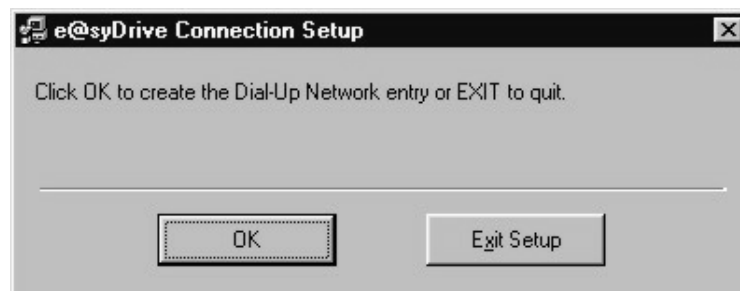

- confirm with "OK"



- confirm "Reboot"

After successful installation, the "e@syDrive" icon appears on the desktop



# e@syDrive 4425, 4426.

## Windows ME

With Windows ME no update of the software for Internet Explorer or RAS software is necessary. The modem driver provided by the setup is also used here for the serial connection. The version of the modem driver is the same for operating systems Win 9x / ME.

After inserting the CD "Installation Assistant" the following messages appear on the screen:

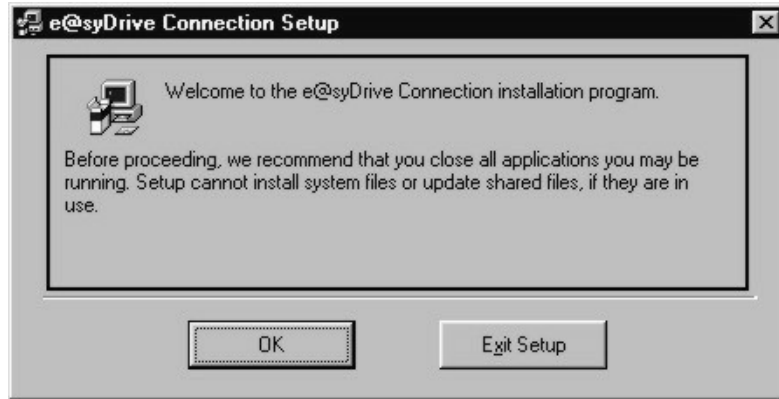

- confirm with "OK"

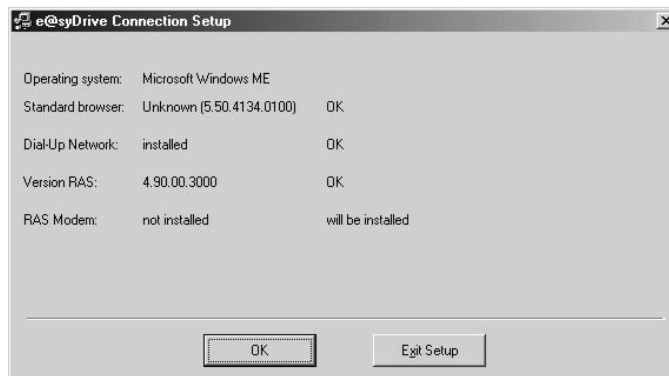

- confirm with "OK"

select location for the connection cable

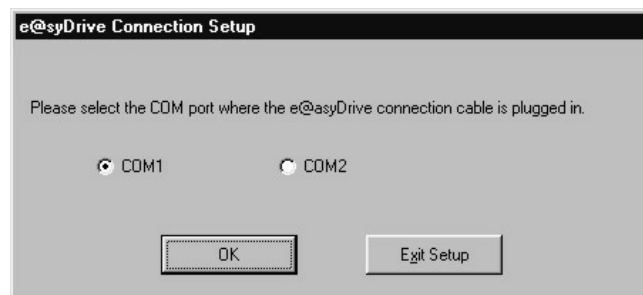

RAS- Modem installed

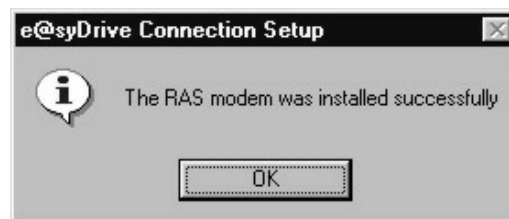

- confirm with "OK"

# e@syDrive 4425, 4426.



- confirm with "OK"



- confirm "Reboot"

after successful installation, the "e@syDrive" icon appears on the desktop.



# e@syDrive 4425, 4426.

## Windows NT

In order to run the setup programme with Windows NT, Service Pack 3 or higher must be installed. In addition, it could be that the Internet Explorer has to be updated to a newer version (4.01 >). The standard installation of Windows NT does not include the data transmission network, which must eventually be installed. In this case, Data Transmission Setup is automatically started by the setup programme.

After inserting the CD "Installation Assistant" the following messages appear on the screen:

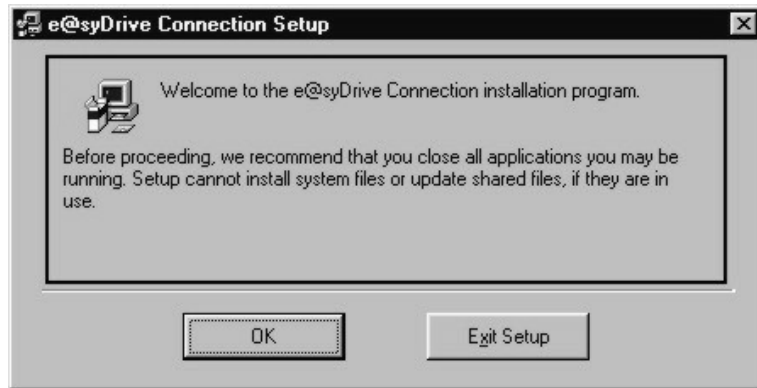

- confirm with "OK"

Installation of the data transmission network



- confirm with "OK"

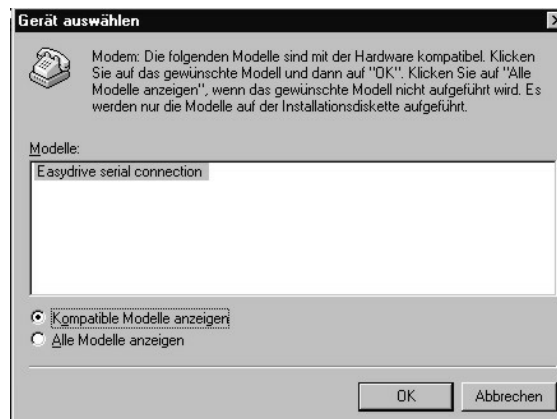

- confirm with "OK"  
RAS modem installed

e@syDrive 4425, 4426.



- confirm with "OK"

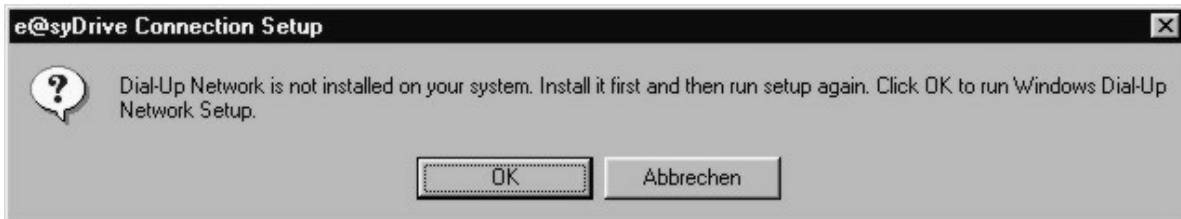

- confirm with "OK"

- Where Windows is installed as standard, the following message appears



- contact your IT specialist (update with Installation CD Windows NT 4)  
- afterwards, restart



- confirm with "OK"

-

## e@syDrive 4425, 4426.

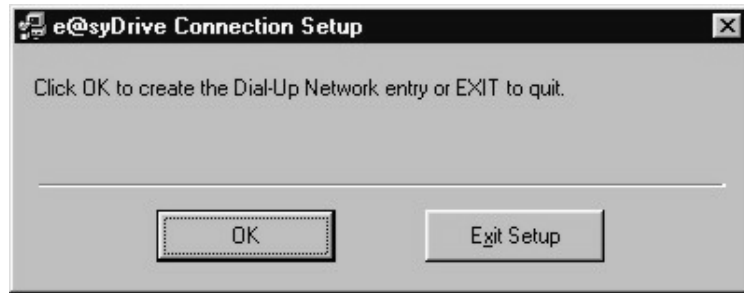

- confirm with "OK"

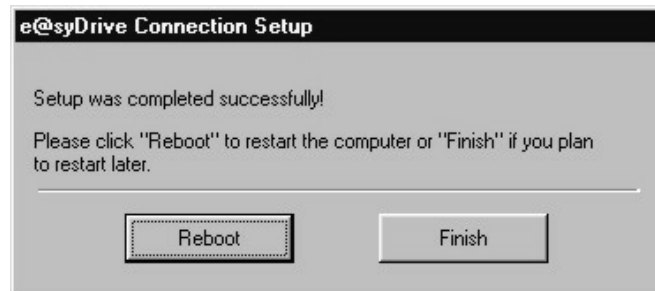

- confirm "Reboot"

After successful installation the "e@syDrive" icon appears on the desktop.



# e@syDrive 4425, 4426.

## Windows XP

Windows XP needs no software update. For the installation of the modem, the Windows 2000 driver is used – this also works with Windows XP. An automatic start of the data transmission connection follows with the programme rasdial.exe.

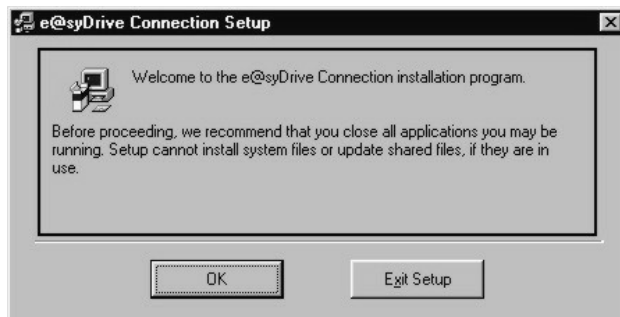

- confirm with "OK"

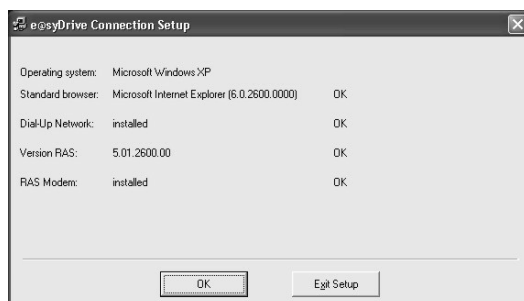

- confirm with "OK"



- confirm with "OK"

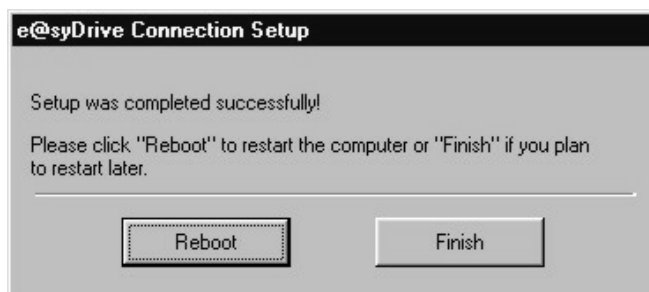

- confirm "Reboot"

After successful installation, the "e@syDrive" icon appears on the desktop.





# e@syDrive 4425, 4426.

## B 3 Operating software

### B 3.1 Language

After starting the operating software via the “e@syDrive” icon (takes about 40 seconds), a page to select the language appears:

Confirm the security warning with “yes”.



Entry page for language selection

By use of the link [industrie.ewl@kavo.de](mailto:industrie.ewl@kavo.de) you can send an E-mail directly to KaVo Industrial Drive Systems (providing this option is configured in the browser).

A click on <http://www.kavo-drives.com> leads you directly to the home page of KaVo Industrial Drive Systems. Clicking on one of the flags to select the language calls up the Basic Parameters page.

## B 3.2 Basic parameters

**Sollwert**

P1-f\_soll  Hz

**Betriebswerte**

P14-f\_motor  Hz  
P15-U\_motor  V~  
P17-I\_mot\_sch  A~

**Grundparameter**

P8-Drehzahl   
P7-Art der Bedienung   
P140-Eingang für Start   
P141-Eingang für f\_soll   
P146-Drehrichtung

**Letzte Störung**

P30-1. Störung

**Weitere Parameter**

Anzeigeparameter

Umrichtertyp e@syDrive 0  
Firmwareversion 0.00  
Seriennummer 0  
PC-SW-Version 2.30

The basic parameters page provides the most important operating and display values  
The individual parameters are fully described in Chapter B 4.6.  
Additional operating windows :

- B 3.1 Language
- B 3.3 Help data
- B 3.4 Display values
- B 3.5 Remote control
- B 3.6 Motor parameters
- B 3.7 U/F Table
- B 3.8 Motor-control parameters
- B 3.9 Special programmes

## B 3.3 Help data

**Hilfe**

Wertebereich = min - max (Werkseinstellung)  
Parameter [ASM, BLDC, BLDCS] = Motor-Parameter für alle drei Motortypen gültig

**Startseite**

P1-f\_soll  
Frequenz-Sollwert (Drehzahlvorwahl) für den Motor.  
Durch P8-Drehzahlanzeige kann P1 von Frequenz- in Drehzahlanzeige umgestellt werden. Die Motor-Polzahl P96-Polzahl wird dabei berücksichtigt.  
Wertebereich: 30 - 4000 Hz (50 Hz)

P7-Betriebsart  
Auswahl von welcher Quelle der Umrichter bedient werden soll.  
Werte:  
PC-Browser - Die Umrichter-Bedienung erfolgt über einen PC-Browser.  
Fernbed. - Start/Stop, Drehzahlsollwert erfolgen über die Fernbedienung. Die Parameter P104 ... P136 für die Fernbedienung sind entsprechend einzustellen.  
Werkseinstellung: PC-Browser

P8-Drehzahlanzeige  
Auswahl der Anzeige für Motor Soll- und Istfrequenzen, in Hz oder in min-1, die Umrechnung der Frequenz in die Drehzahl...

For each page there is help data, which is activated by clicking on the "Help" button.  
To go back to the previous page, click on "Return"

# e@syDrive 4425, 4426.

## B 3.4 Window – display values

Betriebswerte		Fehlermeldungen	
P10-f_soll_akt	0 Hz	P30-1. Störung	<input type="button" value="Hinweis"/>
P11-l_limit_akt	0.0 A~	P31-2. Störung	<input type="text"/>
P13-f_wr_ist	0 Hz	P32-3. Störung	<input type="text"/>
P14-f_motor	0 Hz	P33-4. Störung	<input type="text"/>
P15-U_motor	0.00 V~	P34-5. Störung	<input type="text"/>
P16-U_zkreis	0.00 V-		
P17-l_mot_sch	0.00 A~		
P18-l_mot_wirk	0.00 A~		
P19-P_wirk	0.0 W		
P20-Motorcode	0		

Laufzeitdaten	
P25-Umrichter	0 h
P26-Motor	0 min

On this page, the most important operational values are available online (with approx. 1 Hz) – accumulated faults, running times, as well as customer-specified nominal values. Via the “Information” button, a description of the fault can be called up.

## B 3.5 Window – Remote control

Fernbedienung	
P142-Freigabe FF	Gespenst
P104-Festfreq. FF1	30 Hz
P105-Festfreq. FF2	30 Hz
P106-Festfreq. FF3	30 Hz
P102-Motorcodierung	Motorcode AUS
P129-Auswahl Analog AIN	
P135-f_fern_min	0 Hz
P136-f_fern_max	0 Hz
P137-f_stop_analog	AUS 0 Hz
P110-Eingang IN1	AUS
P111-Eingang IN2	AUS
P112-Eingang IN3	AUS
P113-Eingang IN4	AUS
P114-Eingang IN5	AUS
P115-Eingang IN6	AUS
P120-Relais REL1	AUS
P121-Relais REL2	AUS
P126-L_warn	0.40 A~

In this window the SPS-compatible remote control interface can be configured.

## B 3.6 Window - Motor parameters

The displayed parameters will change according to the choice of motor connected (parameters for P90 type motor)

In accordance with B 4 Configuration, 32 motor-parameter sets can be stored in memory (M1...M32). The following functions can be called up :

- Motor-parameters M1 ...M32 load
- Motor-parameters M1 ...M32 store
- Motor-parameters M1 ...M32 delete
- Load factory setting
- Load KaVo Motor-parameters

## B 3.7 U/f-Tabelle

When an asynchronous motor is configured , the details can be entered in the U/f Table window and visually controlled.

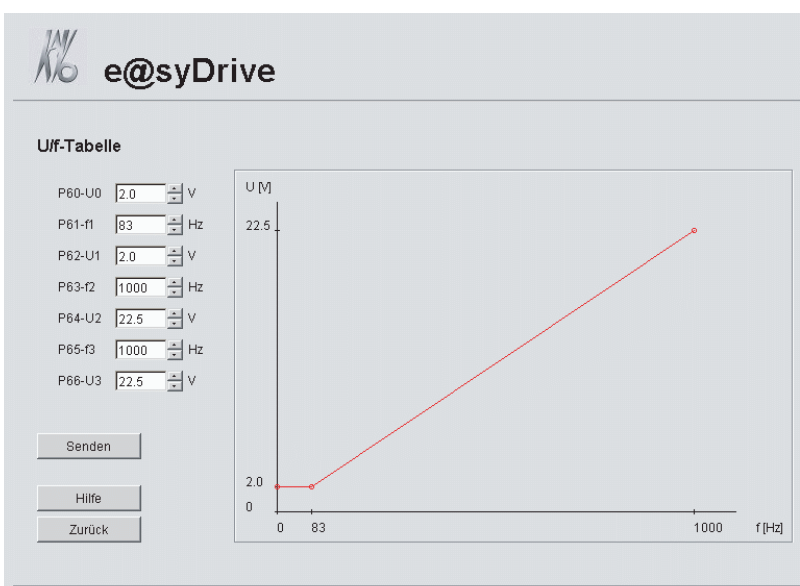

# e@syDrive 4425, 4426.

## B 3.8 Motor-control parameters

The motor-control parameters are available in a window unterlay:

The screenshot shows a software interface for configuring motor-control parameters. At the top left is the e@syDrive logo. Below it, the title "Regelparameter" is displayed. The interface contains several parameter settings, each with a numerical input field and a unit indicator:

- P77-I-Begr-KP: 2 %
- P78-I-Begr-T\_n: ohne I-Anteil, 1 ms
- P79-U-Reg-KP: 5 %
- P80-U-Reg-T\_n: ohne I-Anteil, 1 ms
- P81-N-Reg-KP: 5 %
- P82-N-Reg-T\_n: ohne I-Anteil, 5 ms
- P83-N-Reg-t\_v: ohne D-Anteil, 1 ms
- P84-N-Reg-t\_fil: 1 ms

At the bottom of the window, there are three buttons: "Zurück" (Back), "Hilfe" (Help), and "Senden" (Send).

## B 3.9 Window – Special programmes

Special programmes window

The screenshot shows a software interface for special programmes. At the top left is the e@syDrive logo. Below it, the title "Sonderprogramme" is displayed. The interface contains four buttons arranged vertically:

- Aktorstest
- Gesamte Parameterstruktur
- Werkseinstellung
- Technischer Service

Below the buttons, the text "Datum der Endprüfung: noch nicht erfolgt" is displayed. At the bottom of the window, there are two buttons: "Zurück" (Back) and "Hilfe" (Help).

Test of the remote control interface  
Re-setting parameters to factory settings  
ASS (After-Sales Service) functions

## B 4 Configuration

All inverter-relevant data are accessible in the form of parameters P1 ... P150.  
The configuration is carried out exclusively via the PC-Browser software (see B 4).

### Basic parameters

Higher parameters, upon which further adjustments are dependent (P1 .. P9) (speed values, display adjustments, operating language, mode of operation ...)

### Display values

Pure display values which cannot be changed (P10 ... P39) (voltage, current and frequency values)

### Motor operating parameters

Motor-specific parameters for adapting the motor to the inverters (P41 ... P99)

### Device parameters

Inverter-specific parameters which can be changed (P100 ... P150)

If a parameter cannot be changed (e.g. pure display values), an eye symbol (oo) appears in the first position of the second line in the LCD display H1. This also applies to parameters which can be changed only when the motor is stationary.

If a parameter is not used, depending on the mode or other parameters, it is faded out. It is thus not displayed and also cannot be changed.

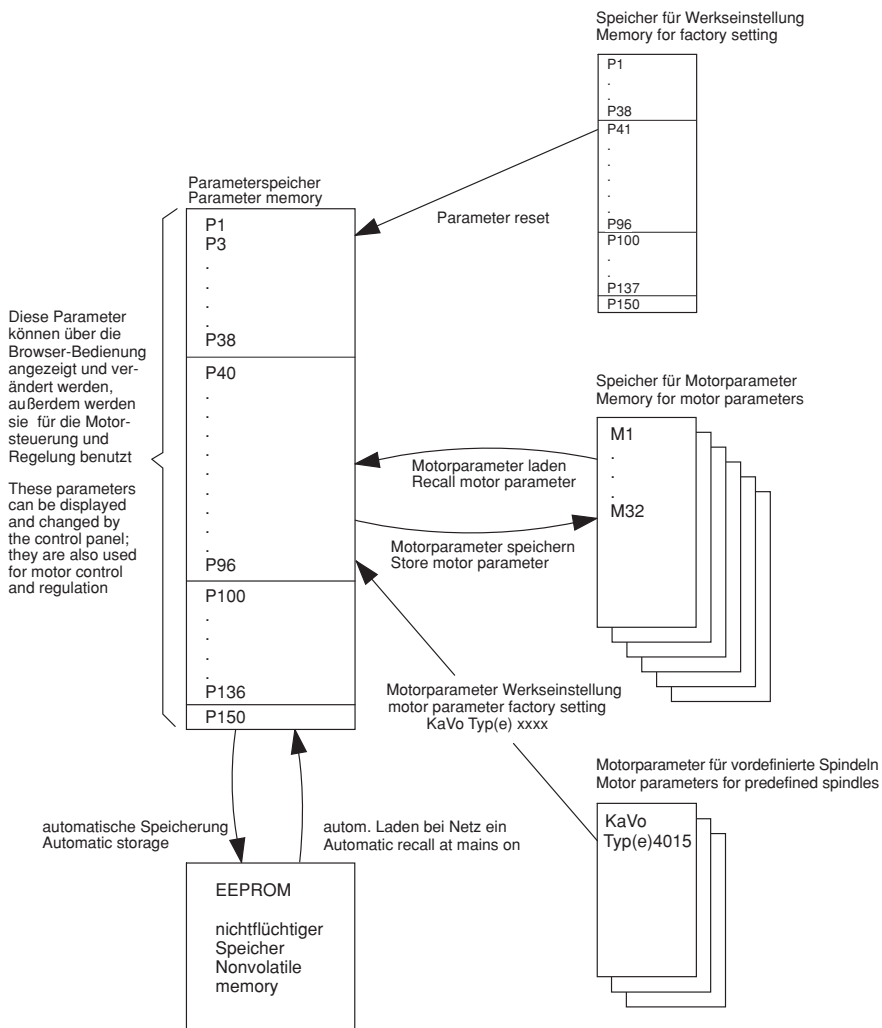

## B 4.1 Special functions

Under special functions, it is possible to establish the default state and to select various utility and test programs which serve as troubleshooting programs and repair aids for the customer and the Technical Customer Service (TKD).

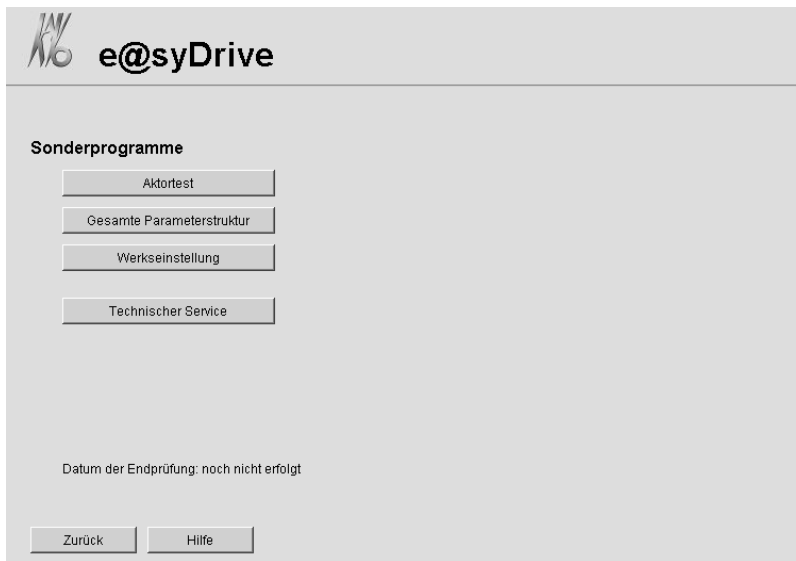

## B 4.2 Aktor-sensor Test

This test serves to check the function of the remote control and the internal signal.

Switch the inverter to mode "no motor". Click to delete the warning.

Temperature sensors, radiator and input voltage UR provide additional information on the condition of the inverter.

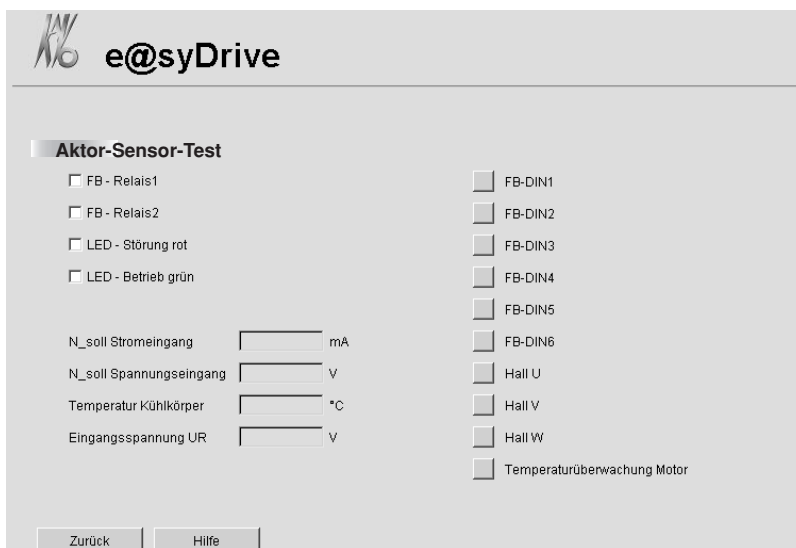

## B 4.3 Complete parameter structure

The parameter structure portrays all the properties of the inverter.  
This reproduction is helpful for configuration and optimizing procedures.

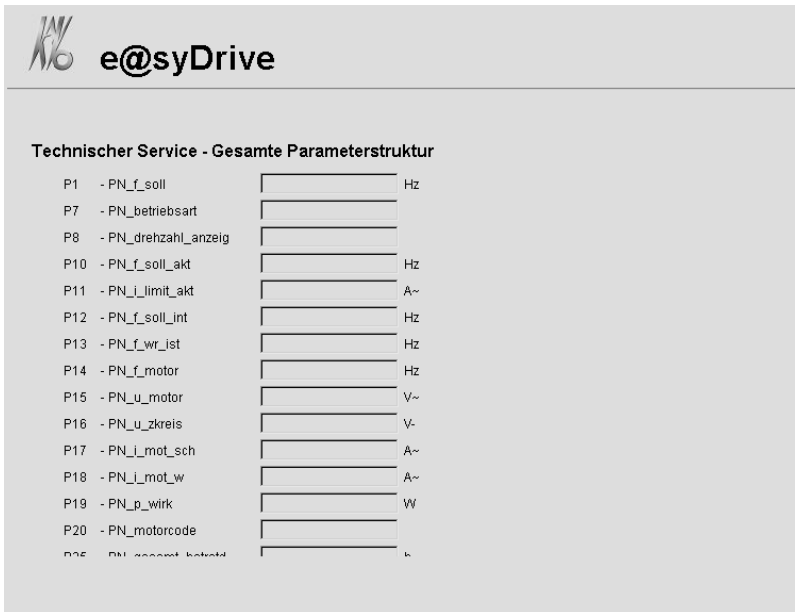

## B 4.4 Factory setting

This function adjusts all parameters P1 ... P150 to the original factory settings. After confirming the security question with OK → , the procedure is implemented. Motor-parameters stored in memory M1 ... M32 are not affected.

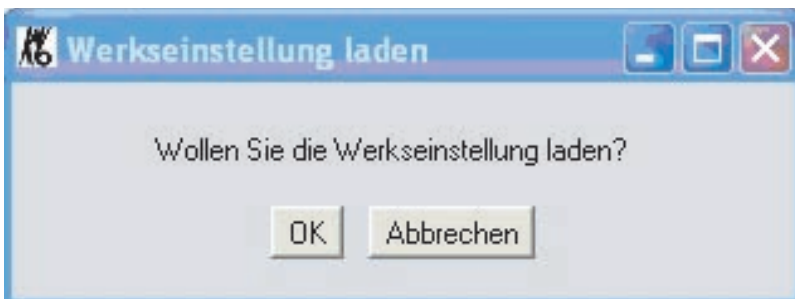

## B 4.5 Technical Service

Various test programmes for Technical Customer Service from KaVo are accommodated under this section.



## B 4.6 Parameter list

This list includes all displayable and alterable parameters.

In the column Change display, the following abbreviations are used:

N = not alterable

S = alterable only when motor stationary

I = always alterable, even when motor running

M = display and alterability dependent on P90-motortype

\* = display dependent on other parameters

Par. No.	Indication in display	Description	Value range, physical value	Unit	Factory setting	Change display
<b>Basic parameters:</b>						
P1	f_soll	Frequenzsollwert Bedienpanel	0...4000	Hz	50	I
P2	Start/stop	start/stop über Browser	on, off, Reset	-	off	I
*P7	Operating	Selection operation	PC-Browser, selectiv	-	selektiv	S
P8	Speed displ	Selection Speed display	in Hz, in min <sup>-1</sup>	-	in Hz	I P
<b>Display values</b>						
P10	f_rated_act	Current frequency setpoint value	0...4000	Hz	-	N
P11	I_limit_act	Current current limit	0.5...16	A~	-	N
P12	f_rated_int	Frequency setpoint value after integrator	0...4000	Hz	-	N
P13	f_wr_act	Actual inverter frequency	0..4000	Hz	-	N
P14	f_motor	Actual motor frequency	0...4000	Hz	-	N
P15	V_motor	Output voltage	0.40	V~	-	N
P16	V_DC_circ	Intermediate circuit voltage	0..75	V-	-	N
P17	I_mot_app	Apparent motor current	0..10	A~	-	N
P18	I_mot_real	Real motor power	0..10	A~	-	N
P19	P_real	Real power	0..400	W	-	N
P20	motor code	Motor coding and motor memory	1..32	-	-	N
P25	t_action	Operating hours counter inverter	0... 65000	h	0	N
P26	t_reset	Operating hours counter motor	0... 65000	min	0	N
P30	1st error	Last error	-	-	0	N
P31	2nd error	Penultimate error	-	-	0	N
P32	3rd error	Third-last error	-	-	0	N
P33	4th error	Fourth-last error	-	-	0	N
P34	5th error	Fifth-last error	-	-	0	N
P36	Inverter	Inverter type	-	-	-	N
P37	SW_panel	Firmware version of panel	-	-	-	N
P38	SW_mot_cont	Firmware version of motor control	-	-	-	N
P39	Serialno.	Serial number of Inverter	-	-	-	N
P40	PC SW Ver.	SW-Version of the PC operation	-	-	-	N
<b>motor-parameters:</b>						
<b>motor-operating values</b>						
P41	f_mot_min	Min. motor frequency	30... 100... 4000	Hz	50	S M
P42	f_mot_max	Max. motor frequency	f mot nom, 100...4000	Hz	P91	S
P43	U_mot_max	Max. motor voltage phase-phase	U mot nenn, 1 ...50.00	V~	P92	S
P44	I_limit	Current limitation (phase current)	0,5...16	A~	1,5*P93	I
P46	t_rise	Ramp time for run-up	0,5... 400	s	5	I
P47	t_fall	Ramp time for fall-down	0,5... 400	s	5	I
P48	t_stop	Ramp time for stop	DC-brake,t down,0,5..400	s	P47	I
*P50	Motor start	Start option, catch circuit	off, main-on, always	-	always	I M
P51	t_start	Start time for microstep operation	without ramp, 0,5 ... 100	s	without ramp	I M
P52	I_start	Startup current microstep oper. BLDC	0,1 ... 16	A~	0,1	I P M *
P53	f_start	Startup frequency microstep operation	1 ... 30	Hz	8	S M
P54	t_off	Inverter switch-off time, startup	200 ... 1000	µs	330	S M
P55	t_DC_brake	DC brake time DC brake	Aus, 0,1... 120	s	Aus	I M
P56	I_DC_brake	DC brake current DC brake	0,1 ... 10	A-	1	I M *
P57	I_DC_stop	DC stop current (at stop)	Aus, 0,1 ... 3	A-	Aus	I
P58	emerg. stop	Select emergency stop at mains failure	inactive, on at mains failure	-	inaktiv	I

# e@syDrive 4425, 4426.

Par. No.	Indication in display	Description	Value range, physical value	Unit	Factory-setting	Change display
<b>U/f characteristic (ASM motor)</b>						
P60	U_boost	Startup voltage at f=0	3%U_nom, 1...50	V~	3%U_nom	IM
P61	f1	1st characteristic point frequency	f_nom, 30... 4000	Hz	f_nom	IM
P62	U1	1st characteristic point voltage	U_nom, 1... 50	V~	U_nom	IM
P63	f2	2nd characteristic point frequency	f_nom, 30... 4000	Hz	f_nom	IM
P64	U2	2nd characteristic point voltage	U_nom, 1... 50	V~	U_nom	IM
P65	f3	3rd characteristic point frequency	f_nom, 30... 000	Hz	f_nom	IM
P66	U3	3rd characteristic point voltage	U_nom, 1... 50	V~	U_nom	IM
<b>Control</b>						
P70	control	Control principle speed control	U/f, I*R	-	U/f-Tab.	IM
P71	I*R factor	I*R compensation gain factor	off, 0,1 ... 10	V/A	off	IM*
P72	loadcomp	Load compensation gain factor	of, 0,1 ... 40	%/A~	off	IM*
P73	komp-t_filt	I*R and load compensation. Filter time	1 ... 1000	ms	20	IM*
P77	I-limtr-KP	Current limitation P-component	2 ... 200	%	40	I
P78	I-limtr-t_n	Current limitation I-component reset time	1 ... 999, without I-part	ms	2	I
P79	U-contr-KP	Voltage control V_WR P-component	5...100	%	20	I
P80	U-contr-t_n	Voltage control I-component reset time	5 ... 999, without I-part	ms	2	I
<b>Monitoring</b>						
P85	motor prot.	Monitoring motor temperature	off, PTC, KTY	-	PTC	I
P86	R_protect	Resistance value for sensor KTY	500...4000	W	1200	I*
<b>Rated motor data (according to rating plate)</b>						
P90	motortype	Motor design	no,ASM, BLDC, BLDCS	-no motor		S
P91	f_mot_nom	Rated motor frequency	30 ... 4000	Hz	100	S
P92	U_mot_nom	Rated motor voltage	0 ... 50	V~	6	S
P93	I_mot_nom	Rated motor current	0,5 ... 16	A~	1,0	S
P94	cos_phi	Cosine phi at nominal load	20 ... 100	%	85	S
P96	no.of poles	Number of poles	2, 4, 6, 8	-	2	S
<b>Device parameters:</b>						
<b>ext. brake resistance</b>						
P102	motorcoding	Motor coding, number of motors	off, 2...32 motors		off	S
<b>Festfrequenzen</b>						
P104	fixfreq.FF1	Fixed frequency FF1 (select with IN3,IN4)	30 ... 4000	Hz	100	I
P105	fixfreq.FF2	Fixed frequency FF2	30 ... 4000	Hz	100	I
P106	fixfreq.FF3	Fixed frequency FF3	30 ... 4000	Hz	100	I
<b>Fernbedienung:</b>						
P110	input IN1	Function digital input IN1	off, start/stop, stop	-	off	S
P111	input IN2	Function digital input IN2	off, Start pulse, reset, links,motor code		off	S
P112	input IN3	Function digital input IN3	off, reset, left, motor code	-	off	S
P113	input IN4	Function digital input IN4	off, reset, left,motor code-		off	S
P114	input IN5	Function digital input IN5	off, reset, left,motor code, FF	-	off	S
P115	input IN6	Function digital input IN6	off, reset, left,motor code, FF	-	off	S
P120	relay REL1	Function relay output REL1	off, various status signals	-	f Rated	I
P121	relay REL2	Function relay output REL2	off, various status signals	-	overload	I
P125	I_warning	var. current limit for relay output	0,4...12	A~	0,4	I
P129	Source AIN1	Source for analog input AIN1	U (0...10 V), I(0...20 mA)	-V	(0...10V)	S
P135	f_rem_min	min. rated freq. of analogue input	0.. 4000	Hz	30	I
P136	f_rem_max	max. rated freq. of analogue input	0.. 4000	Hz	4000	I
P137	f_stop_ana	Stop via analogue signal	off,1... 4000	Hz	Aus	I
P140	Start on	input motor start	Browser, remote control-		AIN1	I
P141	on_f_soll	input Frequenzsollwert	Browser, AIN	-	AIN1	I
P142	release ff	release fixed frequency	stoped, on	-	stoped	I
P146	direction	direction	right, left, remode control	-	rechts	I
P150		End	End mark-	-		

## Description of the individual parameters

### B 4.7 Basic parameters

#### P1-f<sub>rated</sub>

Rated frequency value (speed preselection) for the motor (input on control panel).

By means of parameter P8-speed displ, this parameter can be changed from frequency display to speed display. The number of motor poles P96-no. of poles is taken into account. Here, only values between the min. frequency P41-f-mot-min and the max. frequency P42-f-mot-max can be set.

Minimum value: 30 Hz

Maximum value: 4000 Hz

Factory setting: 50 Hz

#### P2-Start\_Stop

Condition start/stop or reset via browser.

Values: on, off, reset

#### P7-Type of operation

Selection of the source from which the inverter is to be operated with start/stop, setpoint speed value and torque limitation. The digital and analogue output values are always output independently of the setting.

Values: PC-browser- \_ - Operation occurs via the browser software  
Selective. \_ - The inputs for start/stop, speed value and current limitations can be selectively chosen separate over parameters P140 ... P142

Factory setting: Remote control

#### P8-Speed displ

Selection of the display for rated and actual motor speeds, in Hz or in min<sup>-1</sup>, the conversion of the frequency into the speed is performed by the following formula:

Speed = frequency \* 60 / number of poles/2 of the motor (P96-no. of poles).

Values : in Hz - the display is in Hz  
in min<sup>-1</sup> - the display is in min<sup>-1</sup> (revolutions per minute)

Factory setting: in Hz

### B 4.8 Display value

#### P10-f<sub>soll\_akt</sub> (display value)

The valid rated speed value can originate from various sources depending on configuration (panel, remote control analogue input, remote control fixed frequency input). The currently valid value, i.e. the value transmitted to the motor control, is displayed for the user via parameter P10.

By means of parameter P8-speed display, this parameter can be changed from frequency display to speed display, the number of motor poles P96-no. of poles being taken into account.

#### P11-I<sub>limit\_akt</sub> (display value)

The valid torque limitation may originate from P44-I<sub>limit</sub>. The currently valid value is displayed for the user via the parameter P11.

# e@syDrive 4425, 4426.

P13-f\_wr\_ist (display value)

f\_out\_is is the current output frequency of the inverter (inverter frequency).

P14-f\_motor (display value)

f\_motor is the current motor frequency, is the same as the output frequency (P13-f\_out\_act).

By means of parameter P8-speed displ, this parameter can be changed from frequency display to speed display, the number of motor poles P96-no. of poles being taken into account.

P15-U\_motor (display value)

U\_motor is the current motor voltage between two phases.

P16-U\_DC\_circ (display value)

U\_DC\_circ is the current intermediate circuit voltage.

P17-I\_mot\_app (display value)

I\_mot\_app is the current apparent motor voltage in phase U.

P18-I\_mot\_real (display value)

I\_mot\_real is the current real motor current in a phase.

P19-P\_real (display value)

P\_real is the current inverter output power, corresponding to the real power consumed by the motor.

P20-motor\_code (display value)

the currently used motor parameter memory M1...M32 is displayed. If the parameters from the memory have been changed, the display of the memory is not present.

P25-t\_action (display value)

P25-t\_action shows the total operating hours of the device in hours.

The value is read in from the EEPROM.

P26-t\_reset (display value)

P26-t\_reset shows the operating hours of the motor.

The value is read in from the EEPROM.

P30-1st\_error (display value)

1st\_error shows the error number of the last error which occurred.

The value is read in from the EEPROM.

P31-2nd\_error (display value)

2nd\_error shows the error number of the penultimate error which occurred.

The value is read in from the EEPROM.

P32-3rd\_error (display value)

3rd\_error shows the error number of the third-last error which occurred.

The value is read in from the EEPROM.

P33-4th\_error (display value)

4th\_error shows the error number of the fourth-last error which occurred.

The value is read in from the EEPROM.

P34-5th\_error (display value)

5th\_error shows the error number of the fifth-last error which occurred.

The value is read in from the EEPROM.

P36-Inverter (display value)

Inverter shows the inverter type ((e@syDrive z.B. 4425).

P37-SW\_panel (display value)

SW\_panel shows the software version and the date of the operating firmware.

# e@syDrive 4425, 4426.

P38-HW Version (display value)

HW Version shows the Hardware-version of the inverter.

P39-Serialnumber (display value)

Serialnumber shows the Ser. No of the inverter.

P40-SW Version PC-operation (display value)

SW Version PC-operation shows the Software-version of PC-Browser-configurations software.

## B 4.8 Motor operating values

These parameter values are displayed depending on the chosen motor type. The assignment to the individual motor types is shown in square brackets.

P41-f<sub>mot\_min</sub> [ASM, -, -]

Absolutely minimum inverter frequency, set internally to 0 in the case of BLDC and BLDCS motors. In ASM motor, serves for establishing the lower limit of the inverter frequency.

Minimum value: 30 Hz

Maximum value: 100 Hz

Factory setting: 50 Hz

P42-f<sub>mot\_max</sub> [ASM, BLDC, BLDCS]

Absolutely maximum inverter frequency. The output frequency of the inverter is limited to this value to protect the motor.

This value is set to the maximum rated frequency in the case of ASM motors; in the case of BLDC and BLDCS motors, this value should be set about 10% higher than the maximum rated frequency. In addition, this parameter must be set larger than P41-f<sub>mot\_min</sub>

Specific values: [100] f<sub>mot\_nom</sub>

-f<sub>mot\_max</sub> is taken from the nominal motor frequency P91-f<sub>mot\_nom</sub>

Minimum value: 10 Hz

Maximum value: 4000 Hz; 2000Hz at BLDC-Motor

Factory setting: [100] f<sub>mot\_nom</sub> (see P91)

P43-V<sub>mot\_max</sub> [ASM, BLDC, BLDCS]

Maximum motor voltage between two phases, serves for protecting the motor from excessively high voltages. The inverter output voltage is limited to this value.

Specific values: [0] V<sub>mot\_nom</sub>

-V<sub>mot\_max</sub> is taken from the nominal motor voltage P92-V<sub>mot\_nom</sub>

Minimum value: 1 V

Maximum value: 50 V

Werkseinstellung: U<sub>mot\_nom</sub> (see P92)

P44-I<sub>limit</sub> [ASM, BLDC, BLDCS]

Limitation of phase current for normal motor running. The inverter limits the output current to I<sub>limit</sub>.

The stop current (P57-I<sub>DC\_stop</sub>) and, in the case of the BLDC motor, the startup current (P52-I<sub>start</sub>) are unaffected by this.

Specific values: [0.4] 1.5\*I<sub>nom</sub> - I<sub>limit</sub> is set to 1.5 times the nominal motor current from P93-I<sub>mot\_nom</sub>.

Minimum value: 0.5 A

Maximum value: 16 A

Factory setting: [0.4] 1.5\*I<sub>nom</sub> (see P93-I<sub>mot\_nom</sub>)

P46-t<sub>rise</sub> [ASM, BLDC, BLDCS]

Rise time of frequency 0 to P42-f<sub>mot\_max</sub>

The rise time is effective at motor start and in the case of changes of nominal frequency. If the rise time is set too small, the motor current increases up to the current limit P44-I<sub>limit</sub>, thus automatically increasing the rise time.

Minimum value: 0.5 sec

Maximum value: 400 sec

Factory setting: 5 sec

# e@syDrive 4425, 4426.

P47-t\_fall [ASM, BLDC, BLDCS]

Delay from P42-f\_mot\_max to frequency 0.

The delay is effective in the case of changes of nominal frequency and in the case of a motor stop only if

P48-t\_stop is set to t\_fall.

Minimum value: 0.5 sec

Maximum value: 400 sec

Factory setting: 5 sec

P48-t\_stop [ASM, BLDC, BLDCS]

Stop delay time from P42-f\_mot\_max to frequency 0. The inverter reduces its frequency after the specified ramp, and the motor operates as a generator. The rotational energy is converted into heat in the brake resistance. The stop time is effective only at a motor stop, after which DC braking is also performed (see

P55-t\_DC\_brake and P56-I\_DC\_brake).

If t\_stop is set too short, the inverter limits the generator current to the value of P44-I\_limit and the actual stop time of the motor automatically increases but vibrations may occur during the braking process.

Specific values: DC-brake [ASM, -, -]

- At stop, the system switches directly to DC brake, there is no generator braking and the total rotational energy is converted into heat in the rotor.

t\_fall

- t\_stop is set internally as the delay (P47-t\_fall).

Minimum value: 0.5 sec

Maximum value: 400 sec

Factory setting: t\_fall (see P47-t\_fall)

P50-motor\_start [ASM]

Motor start influences the start behaviour of the ASM motors. The catch circuit prevents an overcurrent if the inverter is switched to the running motor. The inverter starts at the maximum motor frequency

P42-f\_mot\_max and reduces its frequency until the inverter frequency has adapted to the motor frequency.

This process takes not more than 1 second.

Values: Normal

-Normal motor start from the frequency P41-f\_mot\_min, no catch circuit.

Catch power on

- The catch circuit is active only when the inverter knows **nothing** about the actual motor speed, for example after power on and reset, unless a speed sensor is used. If the motor was braked via the generator brake, the next motor start takes place without a catch circuit. If the motor is braked only via the DC brake (P48-t\_stop = DC-brake), the catch circuit is active at every motor start.

Catch always

- Catch circuit active at every motor start

Factory setting: Normal

P51-t\_start [-, BLDC, -]

Startup time for microstep startup in BLDC motor from 0 Hz to P53-f\_start.

With t\_start > 0.5 sec sind, P52-I\_start and P53-f\_start must also be input.

In the case of the microstep startup, the BLDC motor is operated as a synchronous motor with constant current (P52-I\_start) . The output frequency is slowly increased from 0 to the start frequency (P53-f\_start), after which the system switches to controlled motor running with e.m.f. measurement. In the case of small centrifugal masses, the start ramp can be switched off or shorter times set. In the case of larger centrifugal masses, longer times should be set.

Specific values: [0.4] without ramp - microstep startup ramp switched off

Minimum value: 0.5 sec - start up with microstep startup ramp

Maximum value: 100 sec

Factory setting: [0.4] without ramp

P52-I\_start [-, BLDC, -]

Startup current for microstep startup, can be selected only if P51-t\_start > 0. Low currents should be set for a soft and quiet start and higher currents for fast start and larger centrifugal masses.

Minimum value: 0.1 A

Maximum value: 16 A

Factory setting: 0.1 A

## e@syDrive 4425, 4426.

P53-f\_start [-, BLDC, -]

Startup frequency for microstep startup. If P51-t\_start is set to [0.4] without ramp, the motor start begins at the frequency f\_start; if a ramp time is set in P51-t\_start, the startup begins at frequency 0 and is slowly increased up to f\_start. On reaching the start frequency, the microstep startup is terminated. If the motor does not start up reliably, f\_start should be increased.

Minimum value: 1 Hz

Maximum value: 30 Hz

Factory setting: 8 Hz

P54-t\_off [-, BLDC, -]

Switch-off time of the inverter.

In the microstep startup, the inverter is repeatedly switched off briefly in a cyclic manner in order to measure the e.m.f. voltage of the BLDC motor; this is used for detecting the position of the rotor at low speeds. In the case of larger inductances of the motor winding, longer times should be set.

**Setting rule:** If the BLDC motor starts up poorly or synchronizes poorly with the motor, longer times should be set; it may also be necessary to increase the startup frequency in P53-f\_start.

Minimum value: 200 µs

Maximum value: 1000 µs

Factory setting: 330 µs

P55-t\_DC\_brake [ASM, -, -]

Time for DC brake in ASM motor,

0 = no DC brake. If this parameter is set to values > 0, P56-I\_DC\_brake should also be set.

Specific values: [0] DC-brake off - There is no DC braking

Minimum value: 0.1 sec

Maximum value: 120 sec

Factory setting: DC- brake off

P56-I\_DC\_brake [ASM, -, -]

Current for DC brake in ASM motor, displayed only if P55-t\_DC\_brake is not set to off.

Minimum value: 0.1 A

Maximum value: 10 A

Factory setting: 1 A

P57-I\_DC\_stop [ASM, BLDC, BLDCS]

Stop current, this current flows in the stopped motor through 2 phases; the 3rd motor phase is currentless and the motor is thus braked (ASM motor) or is kept in a defined position (BLDC or BLDCS motor).

Specific values: Off - With stopped motor, no stop current is output

Minimum value: 0.1 A

Maximum value: 3 A

Factory setting: Off

P58-emerg. stop [ASM, BLDC, BLDCS]

Parameter influences the behaviour on mains failure.

Values: off

- At mains failure, the motor runs out freely and there is no braking.

on at mains off

- The motor is braked with maximum power of the brake resistance as long as the inverter

can still supply itself from the motor voltage.

Factory setting: inactive

## B 4.10 Motor U/f-characteristic

The voltage/frequency table describes the key points of the motor voltage at specific frequencies for the ASM motor.

With the factory setting, characteristic points KP1... KP3 are set to the nominal frequency and the nominal voltage of the motor.



With input from the table, the following must be noted:

■ The frequencies must be equal or must increase in the sequence  $f_1$ ,  $f_2$  and  $f_3$ .

( $P61-f_1 \leq P63-f_2 \leq P65-f_3$ )

■ For identical frequencies, the voltage too must be identical (if e.g.  $P61-f_1 = P63-f_2$ ,  $P62-U_1$  must also be equal to  $P64-U_2$ )

■ If one of the above-mentioned conditions is infringed, a brief warning message is obtained and the value input continues and can be terminated with the  $\leftarrow$  key.

■ In the event of input difficulties, make the input in the sequence P66...P60.

P60-V\_start [ASM, -]

U/f-characteristic: Startup voltage at frequency zero.

The minimum frequency to be output by the inverter is specified in  $P41-f_{mot\_min}$ , and the output voltage at this frequency is calculated using the U/F characteristics.

Specific values  $3\% V_{nom}$

- the startup voltage at  $f=0$  is set internally to the value of 3% of the rated motor voltage from  $P92-V_{mot\_nom}$ .

Minimum value: 1 V

Maximum value: 50 V

Factory setting:  $3\% V_{nom}$

P61-f1 [ASM, -]

U/f-characteristic: Frequency of characteristic point KP1

Specific values:  $f_{nom}$

- the value of the nominal motor frequency from  $P91-f_{mot\_nom}$  is used

Minimum value: 30 Hz

Maximum value: 4000 Hz

Factory setting:  $f_{nom}$

P62-U1 [ASM, -]

U/f-characteristic: Voltage of characteristic point 1

Specific values:  $V_{nom}$

- the value for the rated motor voltage from  $P92-V_{mot\_nom}$  is used

Minimum value: 1 V

Maximum value: 60 V

Factory setting:  $V_{nom}$

P63-f2 [ASM, -]

U/f-characteristic: Frequency of characteristic point KP2

Specific values:  $f_{nom}$

- the value of the nominal motor frequency from  $P91-f_{mot\_nom}$  is used

Minimum value: 30 Hz

Maximum value: 4000 Hz

Factory setting:  $f_{nom}$

P64-V2 [ASM, -]

Specific values:  $V_{nom}$

- the value of the rated motor voltage from  $P92-V_{mot\_nom}$  is used

Minimum value: 1 V

Maximum value: 60 V

Factory setting:  $V_{nom}$



# e@syDrive 4425, 4426.

P65-f3 [ASM, -]

U/f-characteristic: Frequency of characteristic point KP3

Specific values: f<sub>nom</sub>

- the value of the rated motor frequency from P91-f<sub>mot\_nom</sub> is used

Minimum value: 30 Hz

Maximum value: 4000 Hz;

Factory setting: f<sub>nom</sub>

P66-V3 [ASM, -]

U/f-characteristic: Voltage of characteristic point KP3

Specific values: V<sub>nom</sub>

- the value of the rated motor voltage from P92-V<sub>mot\_nom</sub> is used

Minimum value: 1 V

Maximum value: 60 V

Factory setting: V<sub>nom</sub>

## B 4.11 Control

P70-control [ASM, -, -]

Selection of the speed control for ASM motors

Values: U/f table

- Voltage control via U/f table, no rise

- I\*R-load-comp.

- I\*R and load compensation, the motor voltage is adapted as a function of the load. The parameters P71-I\*R-factor, P72-loadcomp and P73-comp-t<sub>filt</sub> should be set.

Factory setting: U/f table

P71-I\*R-factor [ASM, -, -]

Factor of the I\*R compensation, the inverter output voltage is adapted as a function of the motor load.

The aim of the I\*R compensation is to keep the magnetic flux in the motor constant. The I\*R compensation is effective in particular at low speeds or low voltages, and the speeds decrease less sharply under load. The I\*R factor corresponds to the ohmic resistance of the motor, measured between two motor cables.

$$\Delta U = P71-I*R-factor * (P18-I_{mot\_real} - (P93-I_{mot\_nom} * P94-cos\ phi))$$

$$V_{mot} = U_{table} + \Delta U$$

U<sub>table</sub> corresponds to the U/f table voltage, calculated from the values P60...P66

Specific values: off - I\*R compensation switched off

Minimum value: 0.1 V/A (slight rise)

Maximum value: 10 V/A

Factory setting: off

P72-Loadkomp [ASM, -, -]

Factor of the load compensation, the inverter output voltage is adapted as a function of the motor load.

With the load compensation, it is possible to ensure that the motor consumes only little current during idling (little heating up) but that the magnetization current is appropriately increased under load. This makes it possible to reduce the heating up of the motor, and the speed decrease in the load is smaller. The load compensation is applied in particular at medium and high speeds or voltages and supplements the I\*R compensation.

$$\Delta U = U_{table} * P72-Loadkomp * (P18-I_{mot\_real} - (P93-I_{mot\_nom} * P94-cos\ phi))$$

$$V_{mot} = U_{table} + \Delta U$$

U<sub>table</sub> corresponds to the U/f table voltage, calculated from the values P60...P66

Specific values: off - Load compensation switched off

Minimum value: 0.1 %/A (slight rise)

Maximum value: 40 %/A (very sharp rise)

Factory setting: off

P73-komp-t<sub>filt</sub> [ASM, -, -]

Filter time of the I\*R and load compensation

This makes it possible to influence the rapidity of the I\*R and load compensation. If the motor tends to vibrate under load, higher values should be set.

Minimum value: 1 ms

Maximum value: 1000 ms

Factory setting: 20 ms

## e@syDrive 4425, 4426.

### P77-I-limtr-KP [ASM, BLDC, BLDCS]

Only in special cases should this parameter be changed from the factory setting.

P77-I-limtr-KP influences the control (PI) for the motor current limitation, it being possible to set the gain (proportional part) here.

Minimum value: 2 %

Maximum value: 200 %

Factory setting: 40 %

### P78-I-limtr-t<sub>n</sub> [ASM, BLDC, BLDCS]

Only in special cases should this parameter be changed from the factory setting.

P78-I-limtr-t<sub>n</sub> influences the control (PI) for the motor current limitation, it being possible to set the reset time (I-part) here. Longer times make the control slower. If the times are too short, the current control tends to oscillate.

Specific values: without I-part - I-part is switched off

Minimum value: 1 ms

Maximum value: 999 ms

Factory setting: 10 ms

### P79-V-contr-KP [ASM, BLDC, BLDCS]

Only in special cases should this parameter be changed from the factory setting.

P79-V-contr-KP influences the control (PI) for the internal intermediate circuit voltage, it being possible to set the gain (proportional part) here. The motor voltage is generated from the intermediate circuit voltage by the inverter.

Minimum value: 5 %

Maximum value: 100 %

Factory setting: 20 %

### P80-V-contr-t<sub>n</sub> [ASM, BLDC, BLDCS]

Only in special cases should this parameter be changed from the factory setting.

P80-V-contr-t<sub>n</sub> influences the control (PI) for the internal intermediate circuit voltage, it being possible to set the reset time (integral part) here. Longer times make the control slower.

Specific values: without I-part - I-part is switched off

Minimum value: 1 ms

Maximum value: 1000 ms

Factory setting: 2 ms

## e@syDrive 4425, 4426.

### P82-N-contr-t\_n [ASM, BLDC, BLDCS]

This parameter influences the control (PID) for the motor speed, it being possible to set the reset time (integral part) here. Shorter times make the control faster and longer times make it slower.

Specific values: without I-part - I-part is switched off

Minimum value: 5 ms

Maximum value: 999 ms

Factory setting: 200 ms

### P83-N-contr-t\_v [ASM, BLDC, BLDCS]

This parameter influences the control (PID) for the motor speed, it being possible to set the derivative time (D-part) here. Longer times make the control faster and shorter times make it slower.

Specific values: [0] without D-part - D-part switched off

Minimum value: 1 ms

Maximum value: 300 ms

Factory setting: 8 ms

### P84-N-contr-t\_fil [ASM, BLDC, BLDCS]

This parameter influences the control (PID) for the motor speed, it being possible to set the filter before the D-part here. The filter makes the D-part smoother and slightly slower. In the case of longer times, the tendency of the D-part to oscillate is damped.

Minimum value: 1 ms

Maximum value: 300 ms

Factory setting: 50 ms

## B 4.12 Monitoring

P85-motor\_prot. [ASM, BLDC, BLDCS]

The temperature of the motor can be monitored with various sensors, and the sensor type should be set here.

Values: no sensor  
- there is no temperature monitoring of the motors  
PTC  
- Positive temperature coefficient sensor (according to DIN 44081) with fixed switching thresholds, the cut-out temperature is determined by the sensor itself.  
KTY  
- Analogue semiconductor sensor, the switching threshold can be set with P86-R\_protect

Factory setting: no sensor

P86-R\_protect [ASM, BLDC, BLDCS]

Resistance value of the KTY sensor at the cut-out point, selectable only if P85-motor\_prot. is set to KTY.

Minimum value: 500  $\Omega$

Maximum value: 4000  $\Omega$

Factory setting: 1200  $\Omega$

## B 4.13 Nominal motor values



*In this section, the nominal data of the connected motor should be input, this you must doing before you adjustment the other motor parameter.*

The nominal data are shown on the rating plate or the data sheet.

P90-motortype [ASM, BLDC, BLDCS]

Input of motor design.

Values: no motor - no motor defined  
ASM - three-phase asynchronous motor  
BLDC - brushless DC motor without sensors  
BLDCS - brushless DC motor with sensors (not in series version)

Factory setting: no motor

P91-f\_mot\_nom [ASM, BLDC, BLDCS]

Nominal motor frequency according to rating plate in Hertz.

Minimum value: 30 Hz

Maximum value: 4000 Hz

Factory setting: 100 Hz

P92-V\_mot\_nom [ASM, BLDC, BLDCS]

Rated motor voltage according to rating plate.

Minimum value: 0 V

Maximum value: 50 V

Factory setting: 6 V

P93-I\_mot\_nom [ASM, BLDC, BLDCS]

Rated motor current (apparent current in one phase) according to rating plate.

Minimum value: 0.5 A

Maximum value: 10 A

Factory setting: 1.0 A

P94-cos\_phi [ASM, BLDC, BLDCS]

Motor power factor cosine phi according to rating plate.

Minimum value: 20 %

Maximum value: 100 %

Factory setting: 85 %

P96-no. of poles [ASM, BLDC, BLDCS]

Number of poles in the motor. This parameter is used for speed display in  $\text{min}^{-1}$ .



*Note that the number of poles and not the number of pole pairs should be input here.*

Minimum value: 2 poles

Maximum value: 8 poles

Factory setting: 2 poles

# e@syDrive 4425, 4426.

## B 4.14 Device parameters, remote control

### P102-motorcoding

By means of this parameter, the motor coding is switched on and the number of motors used is input (see Section **A 4.5 Motor coding**). A setting to 5...8 motors is possible only if no speed sensor is used, since both functions share the input H1 (X7.3) (see P59-speedsensor).

Only the coding inputs H1...H3 actually required are evaluated.

### P104-fixfreq.FF1

Value of the fixed frequency FF1 which can be selected via the remote control.

By means of parameter P8-speed disp, this parameter can be changed from frequency display to speed display, the number of motor poles P96-no. of poles being taken into account.

Minimum value: 30 Hz

Maximum value: 4000 Hz

Factory setting: 100 Hz

### P105-fixfreq.FF2

Value of fixed frequency FF 2

Minimum value: 30 Hz

Maximum value: 4000 Hz

Factory setting: 100 Hz

### P106-fixfreq.FF3

Value of fixed frequency FF3

Minimum value: 30 Hz

Maximum value: 4000 Hz

Factory setting: 100 Hz

### P110-input IN1

Function of the digital input IN1

Values: Description

OFF Input has no function

/Stop (24V = Start release, 0V = Stop, for Start is P111-input IN2 to be configured to start impulse

Start/Stop 24V = Start, 0V = Stop

### P111- input IN2

Function of the digital input IN2

Values Description

OFF Input has no function

Reverse CCW rotation (24V = CCW)

Reset Reset (Pulse at 24V = trigger reset)

Start impulse An impulse of +24V starts the inverter, after which the input can return to 0V, whereby the inverter remains in the start condition. To stop, configure input IN1 with P110-input IN1 to "Stop", and bring it to 0V

Motor coding Frees up the input for the motor coding, the input has the value Bit4

### P112- input IN3

Function of the digital input IN3

Values Description

OFF Input has no function

Reverse CCW rotation (24V = CCW)

Reset Reset (Pulse at 24V = trigger reset)

Motor coding Frees up the input for the motor coding, the input has the value Bit0

## e@syDrive 4425, 4426.

### P113- input IN4

Function of the digital input IN4

Values	Description
OFF	Input has no function
Reverse	CCW rotation (24V = CCW)
Reset	Reset (Pulse at 24V = trigger reset)
Motor coding	Frees up the input for the motor coding, the input has the value Bit1

### P114- Input In5

Function of the digital input IN5

Values	Description
OFF	Input has no function
Reverse	CCW rotation (24V = CCW)
Reset	Reset (Pulse at 24V = trigger reset)
Motor coding	Frees up the input for the motor coding, the input has the value Bit2
Fixed frequency	Frees up the input for the choice of the fixed frequency, the input has the value Bit1

### P115- Input In6

Function of the digital input IN6

Values	Description
OFF	Input has no function
Reverse	CCW rotation (24V = CCW)
Reset	Reset (Pulse at 24V = trigger reset)
Fixed frequency	Frees up the input for the choice of the fixed frequency, the input has the value Bit0.
Motor coding	Frees up the input for the motor coding, the input has the value Bit3

### P120-relay REL1

Output value of relay REL1

Values:	off: - no function, relay is in opened state.
	operation: - The inverter is ready for operation, the motor can be started.
	failure: - The inverter is in the error state, the motor cannot be started and a reset is required.
	overload: - The motor current has reached the current limit. (P17-I_mot_app >= P44-I_limit, -10% hysteresis)
	N rated reached: - The actual speed of the motor has reached the rated speed (P14-f_motor = P10-f Rated_act, ±10% hysteresis).
	current limit - The real motor current is higher than the current warning threshold (P18-I_mot_real >= P125-I_warning, 10% hysteresis).
	motortemp: - The temperature sensor in the motor indicates that the temperature is too high (see P85-motor prot. and P86-R_protect).
	motor stands: - The motor is stationary, depending on motor type. The ASM motor: if a speed sensor is present, this signal becomes active after the end of the braking process, consisting of generator brake and DC brake (see P48-t_stop and P55-t_DC_brake). After the inverter has been switched on or after a reset, the motor stands signal is inactive. If a speed sensor is configured with P59-speedsensor, this signal becomes active at an actual motor stoppage (f<1Hz). BLDC motor: The signal becomes active if the actual motor stoppage is detected from the e.m.f. voltage.
	motor runs: - This is the inverted motor stands signal.
Factory setting:	n Rated reached

# e@syDrive 4425, 4426.

## P121- relay REL2

Output value of relay REL2.

Values: - see under parameter P120-relay REL1

Factory setting: 3]overload

## P125-I\_warning

Value of the variable current limit for the relay output, this can be used for detecting a specific motor load, a relay output (P120- relay REL1 ... P123- relay REL4) must be configured with the current limit function for this purpose. The value has no effect on the current limitation.

Minimum value: 0.4 A

Maximum value: 8 A

Factory setting: 0.4 A

## P129- Source Analog AIN1

Selection of the source for Ain1

value: U(0...10V)

- SPS-kompatibel 0...10 V

I(0...20mA)

- SPS-kompatibel 0...20 mA

Factory setting: U(0...10V)

## P135-f\_rem\_min

Minimum rated frequency for analogue rated frequency default AIN1 at V<sub>e</sub> = 0V. This parameter is evaluated only if P130-analogue AIN1 is configured for rated frequency.

By means of parameter P8-speed displ, this parameter can be changed from frequency display to speed display, the number of poles of the motor P96-no. of poles being taken into account.

Minimum value: 30 Hz

Maximum value: 4000 Hz

Factory setting: 30 Hz

## P136-f\_rem\_max

Maximum rated frequency for analogue rated frequency default AIN1 at V<sub>e</sub> = 10V. This parameter is evaluated only if P130-analogue AIN1 is configured for rated frequency.

By means of parameter P8-speed displ, this parameter can be changed from frequency display to speed display, the number of poles of the motor P96-no. of poles being taken into account.

special valve: [0] f<sub>mot\_max</sub> - valve of P42-f<sub>mot\_max</sub> is used to automatically adjust to maximum frequency of motor.

Minimum value: 30 Hz

Maximum value: 4000 Hz

Factory setting: 4000 Hz

## P137-f\_stop\_ana

Stop frequency from analogue rated frequency signal; this makes it possible to achieve an automatic motor stop with counterclockwise rotation of the nominal value potentiometer or analogue voltage 0 V.

The motor is automatically stopped if the rated frequency default at analogue input AIN1 falls below the value of this parameter. By means of parameter P8-speed displ, this parameter can be changed from frequency display to speed display, the number of poles of the motor P8-no. of poles being taken into account.

In this context, also see the parameter P135-f<sub>rem\_min</sub> and P136-f<sub>rem\_max</sub>.

special Values: off - no automatic stop

f<sub>mot\_min</sub> - the value from P41-f<sub>mot\_min</sub> is used

Minimum value: 30 Hz

Maximum value: 4000 Hz

Factory setting: off

## P140-Input Start

With this, the input for the motor start is determined. This parameter is displayed and evaluated only when P7-Operational Mode is set to Selective.

Value: PC browser -start/stop is implemented via the control panel (start, nominal values)

Remote control start/stop is implemented via inputs In1 and In2 of the remote control - see

P110-input IN1 and P111-input IN2.

Factory setting: Remote control

## e@syDrive 4425, 4426.

### P141- Input f\_value

With this, the input for the frequency nominal value is determined. This parameter is displayed and evaluated only when P7-Operational mode is set to Selective. Via P142-Release FF, alternative fixed frequency nominal values - so-called fixed frequencies - can be activated. The method is clearly described in Section A4.6.

Value: PC browser - The value of the control panel in P1 – f value is used as the frequency value  
AIN - The frequency value is calculated from the voltage at the analogue input AIN. The frequency limits are set via parameters P135-f\_fern\_min and P136-f\_fern\_max. The calculated value can be seen in P10-f\_soll\_akt.

Factory setting : AIN

=

### P142-Release FF

With this, the fixed frequencies are made available. This parameter is displayed and evaluated only when P7-Operational mode is set to Selective. The method is clearly described in Section A4.6..

Value: Blocked - The fixed frequencies are blocked. The nominal value load is effected from the input indicated in P141-input.f\_value.  
On - The fixed frequencies are available. The choice of which frequency is to be used as the nominal value is implemented via the digital inputs IN5 und IN6. The fixed frequencies themselves are stored in the parameters P104-frequencyFF1 to P106-frequencyFF. The current value can be seen in P10-f\_value akt.

Factory setting: Blocked

### P146-Direction of rotation

Here the rotational direction of the motor is determined. Alternatively, a digital control input for switching the direction of rotation can be used. \_

Value: Forward - Rotation to the right  
Reverse - Rotation to the left  
Remote control - The direction of rotation is provided by a control input of the remote control. So that the input can function as a switchover, one of the parameters from P111-Input In2 to P115-Input In6 has to be set to Reverse.

Factory setting: Forward rotation

### P150-End (Display value)

Last parameter number, serving as the end mark.



## B 5 Error messages

If the LED H5 (yellow) flashes as a warning, the motor can continue to run. If a fault is detected, LED H5 will flash and the motor will be stopped.

Applicable to both types of errors:

 *\*The number of flashes corresponds to the Warning or Fault Number. This applies only to fault/warning numbers up to 9.*

To release the error condition, a Reset must be triggered (either via the PC browser or a remote control reset). With a reset, a complete initialization of the unit will be set in motion. If the error continues to exist, the error display will re-appear.

The last five error messages are stored in the parameters P30-1.Fault to P34-5.Fault.Warning messages are not taken into account here – thereby allowing the fault history to be tracked.

### B 5.1 Hold function

At the time of occurrence of the error, all display values are stored.

As long as the error condition exists, all values from the Hold Memory will be displayed in the window Display Values (see B.3.1).

A fault symbol appears in the PC browser.

The Hold function allows, retrospectively, the determination of the operating point which led to the error condition being triggered.

After resetting, the Hold Display and all values in the Hold Memory are deleted.

### B 5.2 Faults and Warnings

- \* 1 Motor current too high, Inverter limit exceeded
- \* 2 No motor in Parameter - P90-Motor type configured
- \* 3 Earth leakage in motor or supply wire
- \* 4 Inverter cooling-chamber temperature too high
- \* 5 Fault in rectifier during self-test
- \* 6 Rectifier overload
  
- 10 Current limitation active - Warning
- 11 Motor temperature too high
- 12 Motor current in generator drive too high, Inverter limit exceeded
- 13 Rectifier intermediate circuit voltage U\_WR too high
- 14 Input supply voltage too low
- 15 Input supply voltage too high
- 16 Peak current fault in rectifier
- 17 Motor connection interrupted
- 18 Nominal speed limit active
- 19 Emergency motor-stop active, mains voltage insufficient
- 20 Remote control analogue input AIN1 voltage greater than 11V or 0,22A
- 21 Remote control analogue input AIN2 voltage greater than 11V or 0,22A
- 24 Invalid code for motor coding
- 25 Motor coding changed while motor running
- 26 Unused motor parameter memory for motor coding
- 45 Watchdog-reset at motor control
- 52 Fault in direct-current plate during self-test
- 53 Short circuit or earth leakage in direct-current plate
- 54 Brake-chopper defective, or braking resistance interrupted during self-test
- 57 Actual motor speed too high
- 58 BLDC-Motor does not start
- 62 Fault when accessing the EEPROM data bank
- 63 Fault when reading the parameter from the EEPROM data bank

## B 5.3 Description of all errors and warnings

W = Warning message, inverter still ready for operation

E= Error message, serious fault, inverter not ready for operation, a reset must be triggered

F = Fault C = Cause R = Rectification

**F: 1 W** Warning. Motor current has reached the current limit (P44-I\_limit)

**C:** Motor too highly loaded, rise time P46-t\_rise too short, startup current P52-I\_start too large

**R:** Reduce load, adapt parameter

**F: 2 W** No motor defined

**C:** Parameter P90-motor\_type set to "no motor"

**R:** Set parameter P90-motor\_type, presumably the inverter is still not configured, see Section B 2 Fast commissioning

**F: 3F** Earth leakage in motor

**C:** Short circuit in motor or supply wire

**R:** Change or repair the motor. Check supply wire

**F: 4 E** Temperature monitoring Inverter cooler

**C:** Inverter overloaded, cooler too hot

**R:** Reduce load, check output currents

**S: 5 F** Fehler im Wechselrichter beim Selbsttest

**U:** Hardware-Fehler im Leistungsteil

**B:** Bleibt der Fehler trotz mehrmaligem EIN/AUS-Schalten bestehen muss der Umrichter zur Reparatur.

**F: 5F** Fault in rectifier during self-test

**C:** Performance-component failure

**R:** Switch on and off several times. If the fault still exists, send Inverter for repair

**F: 6F** Rectifier overload

**C:** Performance-component failure. Fault in motor, or motor supply wire

**R:** Exchange motor or supply wire. Switch on and off several times. If the fault still exists, send Inverter for repair

**F: 10 E** Inverter output current too large(15A)

**C:** Motor current too high, overload

**R:** Reduce load, check parameter P44-I\_limit

**F: 11 E** Temperature monitoring Motor

**C:** Motor too hot, possibly sensor cable break

**R:** Cool motor reduce load, test sensor and check P85-motor\_prot. and P86-R\_protect

**F: 12 E** Inverter overcurrent protection Generator operation (15 A)

**C:** Generator current too high

**R:** Increase ramp times P47-t\_fall or P48-t\_stop, if necessary activate catch circuit (P50-motor\_start)

**F: 13 E** Voltage monitoring Intermediate circuit voltage (380 V)

**C:** ASM motor fall time too short

**R:** Adapt parameter P47-t\_fall

**F: 14 E** Monitoring Mains undervoltage

**C:** Mains voltage too low

**R:** Test mains voltage, test mains connection

**F: 15 E** Monitoring Mains overvoltage

**C:** Mains voltage too high

**R:** Test mains voltage, test mains connection

**F: 16 E** Overcurrent protection in inverter (peak current)

**C:** Inverter overloaded, motor short-circuit or earth fault

**R:** Reduce load, check motor and supply cable for short-circuit and earth fault

# e@syDrive 4425, 4426.

**S:** 17 W Motor connection broken

**C:** No KL motor connected or a motor phase is interrupted

**R:** Check motor connection, adapt parameter `P90-motortype`

**F:** 18 W-Nominal speed limit active. The internal nominal speed of the motor control (`P12-fratedint`) is limited to the maximum inverter frequency `P42-fmotmax`.

**C:** `P1-frated` or rated value of analogue input too high

**R:** Check rated parameter value `P1-frated`, frequency limits for rated value for remote control `P135-fremmin` and `P136-fremmax` and fixed frequencies `P104 ... P107`, for checking the current rated value `P10-fratedact`.

**F:** 19 W- Motor emergency stop is activated

**C:** Mains voltage interruption or mains input voltage too low.

**R:** Stop motor and start again on control panel, check parameter `P58-emergstop`, check mains voltage.

**S:** 20 W- Input voltage at AIN1 is higher than 11 volt.

**C:** Input voltage too high

**R:** Reduce voltage, check wiring

**S:** 21 W- Input voltage at AIN2 is higher than 11 volt.

**C:** Input voltage too high

**R:** Reduce voltage, check wiring

**S:** 24 W - Inadmissible code for motor coding

**C:** Motor coding input set to a higher code number than motors configured in `P102-motorcoding`, e.g. coding input is 4 and only 3 motors configured in `P102`

**R:** Check signal values at X7 (also see `P20-motorcode`) or parameter `P102-Motorcoding`.

**S:** 25 W - Motor coding changed while motor running

**C:** Motor coding input at X7 changed while motor running

**R:** Check signal values at X7, they may not change while the motor is running (also see `P20-motorcode`).

**S:** 26 W - Unused motor parameter memory for motor coding.

**C:** The value at motor coding input X7 indicates an empty parameter memory `M1...M32`

**R:** Check signal values at X7 (also see `P20-motorcode`) or store parameter for corresponding motor (see Section

**S:** 45 W Watchdog reset on motor control

**C:** Strong EMC interference on motor control circuit board

**R:** Warning indication is automatically reset after 10 seconds and motor continues to run.

**F:** 52F Fault in direct-current plate during self-test

**C:** Performance-component failure

**R:** Switch on and off several times. If the fault still exists, send Inverter for repair

**F:** 53F Short circuit or earth leakage in direct-current plate

**C:** Performance-component failure

**R:** Check wiring. Switch on and off several times. If the fault still exists, send Inverter for repair

**F:** 54W Brake-chopper defective, or braking resistance interrupted during self-test

**C:** Performance-component failure

**R:** Switch on and off several times. If the fault still exists, send Inverter for repair: motor can still be operated

**F:** 57W Actual motor speed too high

**C:** Actual speed lies 10% over nominal speed. Motor cannot follow the nominal speed. Motor externally driven.

**R:** Set the nominal speed at a lower level

## e@syDrive 4425, 4426.

**F:** 58F BLDC motor does not start  
**C:** Despite several attempts, the motor does not start  
**R:** Check motor and supply lines. Adjust P46 t-high, P51 t-run, P52 I-run

**F:** 62W Fault when accessing the EEPROM data bank  
**C:** Hardware failure  
**R:** Switch on and off several times. If the fault still exists, send Inverter for repair: motor can still be operated

**F:** 63W Fault when reading the parameter from the EEPROM data bank  
**C:** Reading/writing fault in EEPROM  
**R:** Reset EEPROM via Special Programme/Factory Setting.

**Warranty conditions**

Under valid KaVo delivery and payment conditions, KaVo gives a warranty of satisfactory function and freedom from faults in material and manufacture for the duration of 12 months from the date of sale certified by the vendor.

In the case of justifiable complaints, KaVo shall supply spare parts or carry out repairs free of charge. KaVo accepts no liability for defects and their consequences which have arisen or could have arisen as a result of natural wear, improper handling, cleaning or maintenance, noncompliance with the maintenance, operating and connecting instructions, corrosion, impurities in the air supply or chemical or electrical influences which are unusual or not admissible in accordance with KaVo's instructions. The warranty claims shall become null and void if defects or their consequences can be attributed to interventions in or modifications to the product. Warranty claims can only be validated if they are notified immediately in writing to KaVo.

Wir, We, KaVo ELEKTROTECHNISCHES WERK GmbH

KE50

Wangener Str. 78  
D-88299 Leutkirch im Allgäu

erklären, dass die Produkte  
declare that the products

**Frequenzumrichter Typen 4425, 4426**  
**frequency inverter types 4425, 4426**

auf das sich diese Erklärung bezieht, mit den wesentlichen Schutzanforderungen gemäß den Bestimmungen der Richtlinie(n)  
-to which this declaration relates complies with the essential safety requirements in accordance with the provisions of the Directive(s)

89/336/EWG (EMV-Richtlinie)  
73/23/EWG (Niederspannungsrichtlinie)

übereinstimmt.

Zur Beurteilung des Erzeugnisses wurden folgende Normen oder normativen Dokumente angewandt:  
The following standards or normative documents were used for assessing the product:

EN 61800-5-1:2003 Elektrische Leistungsantriebssysteme mit einstellbarer Drehzahl  
EN 61000-3-2:2000 Elektromagnetische Verträglichkeit (EMV)  
Grenzwerte - Begrenzung von Spannungsänderungen,  
Spannungsschwankungen und Flicker  
EN 61800-3:1996  
+ A11:2000 EMV-Produktnorm für drehzahlveränderbare elektrische Antrieb

Leutkirch, 24.06.2004

M.Mohr  
Geschäftsführer  
Managing Director



**KaVo.Drive Systems**

D-88299 LEUTKIRCH.  
Telefon 075 61/86-0 Fax 075 61/86-371  
Internet: [www.kavo-drives.com](http://www.kavo-drives.com)