

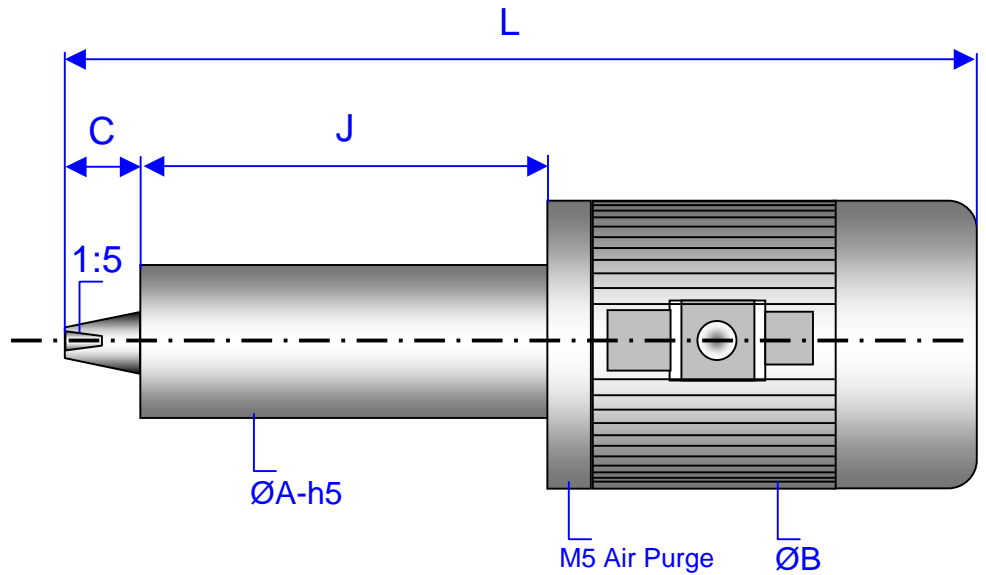

HIGH FREQUENCY SPINDLE HR
 ALL CRITICAL PARTS ARE HARDENED AND GROUND.
 ALL SPINDLES ARE BALANCED.



TYPE	A-h5	C	J	L	B	RPM	KW	LUBRICATION
HR038090	38	23						
HR050170	50	23		349	95	18,000	0.6	Grease
HR050300	50	28	300		155	3,000	0.75	Grease
HR050400	50	23	400		156	3,000	0.75	Grease
HR060160	60	23		370	128	2,800	0.37	Grease
HR060185	60	45		573	176	12,000	2.2	Grease
HR060230	60					12,000		Grease
HR060400	60	29	400		156	3,000	1.1	Grease
HR070250	70	36		458	176	3,000	1.1	Grease
HR080200	80							Grease
HR080250	80	45		573	176	9,000	2.2	Grease
HR100350	100	350	59	709	195	4,500	4.5	Grease
HR110239	110	110		700	150			Grease
HR120239	120	120		700	150			Grease
HR120400	120	97		797	175	9,000	13	Grease
HR140350	140	72		662	220	12,000	12	Grease
HR140450	140	106		946	256	3,000	6	Grease

ALL DIMENSIONS IN <MM>

Centerline, Inc.

2110 North Ash
 Ponca City, OK 74601

Ph: (580) 762-5451
 (800) 696-2865
 Fax: (580) 762-4722

Email: info@centerline-inc.com
 Website: www.centerline-inc.com